

# Appendix A

## Traffic Data Used in the Assessment of Existing Transportation Conditions







# Appendix A-1

## Turning Movement Counts – Carp Road and Highway 417 N Westbound





**CARP and HWY 417 N WESTBOUND**  
(ULRS Listing RR- 5 & HWY417 N)

**Survey Date:** Tuesday 16 June 2009  
**Conditions:** dry  
**Start Time:** 0700

**Total Observed U-Turns**  
Northbound: 0 Southbound: 0  
Eastbound: 0 Westbound: 1

**AADT Factor**  
Tuesday in June is  
9

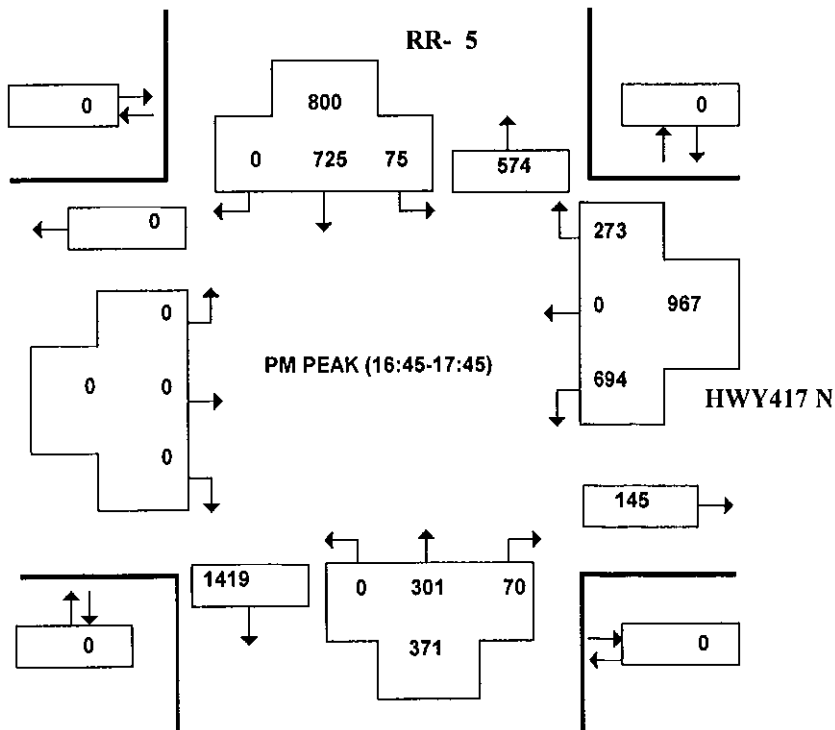
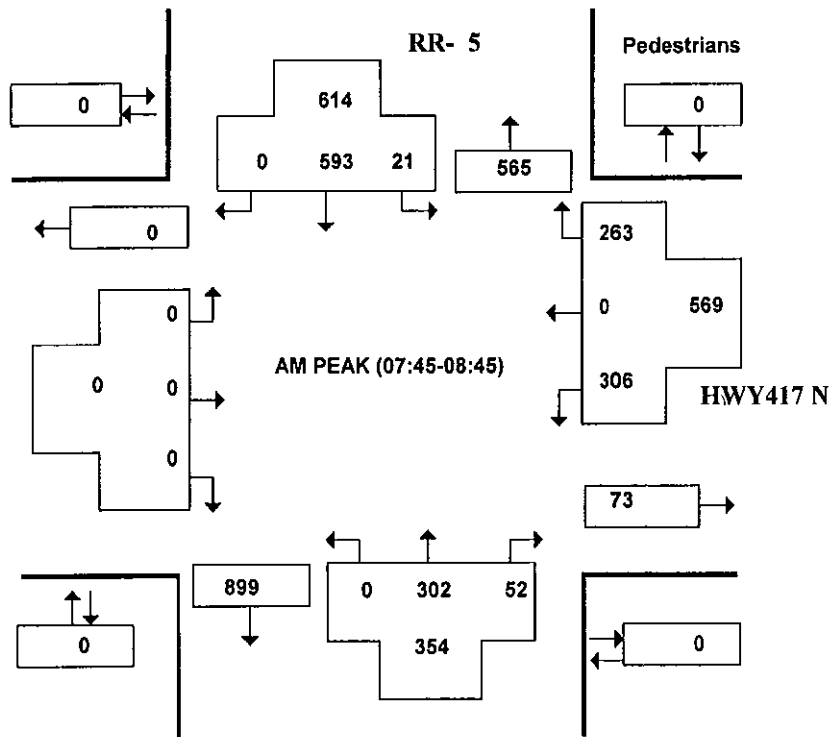

Vehicular Turning Movements - Summary

**CARP and HWY 417 N WESTBOUND**

(ULRS Listing RR- 5 & HWY417 N)

Survey Date: Tuesday 16 June 2009  
 Conditions: dry  
 Start Time: 0700

Total Observed U-Turns  
 Northbound: 0 Southbound: 0  
 Eastbound: 0 Westbound: 1

AADT Factor  
 Tuesday in June is  
 9

Time Period	RR- 5									HWY417 N									
	Northbound			SUB TOT	Southbound			SUB TOT	STR TOT	Eastbound			SUB TOT	Westbound			SUB TOT	STR TOT	GRAND TOT
	LT	ST	RT		LT	ST	RT			LT	ST	RT		LT	ST	RT			
07:00-08:00	0	274	33	307	27	398	0	425	732	0	0	0	0	218	0	261	479	479	1211
08:00-09:00	0	305	55	360	13	603	0	616	976	0	0	0	0	325	0	230	555	555	1531
09:00-10:00	0	259	43	302	7	346	0	353	655	0	0	0	0	149	0	105	254	254	909
11:30-12:30	0	145	59	204	9	485	0	494	698	0	0	0	0	353	0	166	519	519	1217
12:30-13:30	0	200	53	253	25	483	0	508	761	0	0	0	0	354	0	199	553	553	1314
15:00-16:00	0	249	152	401	13	580	0	593	994	0	0	0	0	440	0	240	680	680	1674
16:00-17:00	0	201	75	276	62	638	0	700	976	0	0	0	0	586	0	225	811	811	1787
17:00-18:00	0	323	66	389	78	657	0	735	1124	0	0	0	0	693	0	278	971	971	2095
<b>8.0 HR TOTAL</b>	<b>0</b>	<b>1956</b>	<b>536</b>	<b>2492</b>	<b>234</b>	<b>4190</b>	<b>0</b>	<b>4424</b>	<b>6916</b>	<b>0</b>	<b>0</b>	<b>0</b>	<b>0</b>	<b>3118</b>	<b>0</b>	<b>1704</b>	<b>4822</b>	<b>4822</b>	<b>11738</b>

EQU. 12 HR TOTAL 0 2718 745 3463 325 5824 0 6149 9612 0 0 0 0 04334 0 2368 6702 6702 16314

Note: These values are calculated by multiplying the totals by the appropriate expansion factor.

AVG. 12 HR TOTAL 0 2446 670 3116 292 5241 0 5533 8649 0 0 0 0 0 3900 0 2131 6031 6031 14680

Note: These volumes are calculated by multiplying the Equivalent 12 hr. totals by the AADT factor.

AVG. 24 HR TOTAL 0 3204 877 4081 382 6865 0 7247 11328 0 0 0 0 0 5109 0 2791 7900 7900 19228

Note: These volumes were calculated by multiplying the Average Daily 12 hr totals by 1.31.

AM TOTAL (0700-0900) 0 579 88 667 40 1001 0 1041 1708 0 0 0 0 0 543 0 491 1034 1034 2742

PM TOTAL (1530-1730) 0 483 198 681 120 1283 0 1403 2084 0 0 0 0 0 1255 0 481 1736 1736 3820



Vehicular Turning Movements (15 Min. Volumes)

**CARP and HWY 417 N WESTBOUND**

(ULRS Listing RR- 5 & HWY417 N)

Survey Date: Tuesday 16 June 2009  
 Conditions: dry  
 Start Time: 07:00

**Total Observed U-Turns**  
 Northbound: 0 Southbound: 0  
 Eastbound: 0 Westbound: 1

**AADT Factor**  
 Tuesday in June is  
 9

Time Period	RR- 5									HWY417 N									GRAND TOT
	Northbound			SUB TOT	Southbound			STR TOT	Eastbound			SUB TOT	Westbound			SUB TOT	STR TOT		
	LT	ST	RT		LT	ST	RT		LT	ST	RT		LT	ST	RT				
07:00-07:15	0	37	8	45	0	58	0	58	103	0	0	0	0	42	0	46	88	88	191
07:15-07:30	0	69	4	73	9	124	0	133	206	0	0	0	0	41	0	54	95	95	301
07:30-07:45	0	90	8	98	9	84	0	93	191	0	0	0	0	76	0	89	165	165	356
07:45-08:00	0	78	13	91	9	132	0	141	232	0	0	0	0	59	0	72	131	131	363
08:00-08:15	0	73	19	92	0	153	0	153	245	0	0	0	0	80	0	60	140	140	385
08:15-08:30	0	82	14	96	6	150	0	156	252	0	0	0	0	71	0	77	148	148	400
08:30-08:45	0	69	6	75	6	158	0	164	239	0	0	0	0	96	0	54	150	150	389
08:45-09:00	0	81	16	97	1	142	0	143	240	0	0	0	0	78	0	39	117	117	357
09:00-09:15	0	66	11	77	3	99	0	102	179	0	0	0	0	55	0	35	90	90	269
09:15-09:30	0	59	10	69	1	118	0	119	188	0	0	0	0	48	0	38	86	86	274
09:30-09:45	0	70	19	89	0	0	0	0	89	0	0	0	0	0	0	0	0	0	89
09:45-10:00	0	64	3	67	3	129	0	132	199	0	0	0	0	46	0	32	78	78	277
11:30-11:45	0	30	17	47	1	115	0	116	163	0	0	0	0	55	0	33	88	88	251
11:45-12:00	0	34	13	47	0	141	0	141	188	0	0	0	0	90	0	39	129	129	317
12:00-12:15	0	33	13	46	3	92	0	95	141	0	0	0	0	107	0	29	136	136	277
12:15-12:30	0	48	16	64	5	137	0	142	206	0	0	0	0	101	0	65	166	166	372
12:30-12:45	0	39	17	56	9	125	0	134	190	0	0	0	0	85	0	49	134	134	324
12:45-13:00	0	82	14	96	6	129	0	135	231	0	0	0	0	105	0	44	149	149	380
13:00-13:15	0	51	10	61	0	114	0	114	175	0	0	0	0	111	0	45	156	156	331
13:15-13:30	0	28	12	40	10	115	0	125	165	0	0	0	0	53	0	61	114	114	279
15:00-15:15	0	53	36	89	1	156	0	157	246	0	0	0	0	52	0	54	106	106	352
15:15-15:30	0	70	32	102	0	152	0	152	254	0	0	0	0	109	0	67	176	176	430
15:30-15:45	0	68	47	115	0	153	0	153	268	0	0	0	0	130	0	64	194	194	462
15:45-16:00	0	58	37	95	12	119	0	131	226	0	0	0	0	149	0	55	204	204	430
16:00-16:15	0	39	14	53	13	147	0	160	213	0	0	0	0	117	0	41	158	158	371
16:15-16:30	0	46	22	68	24	163	0	187	255	0	0	0	0	168	0	71	239	239	494
16:30-16:45	0	47	17	64	16	152	0	168	232	0	0	0	0	168	0	58	226	226	458
16:45-17:00	0	69	22	91	9	176	0	185	276	0	0	0	0	133	0	55	188	188	464
17:00-17:15	0	83	19	102	18	177	0	195	297	0	0	0	0	212	0	63	275	275	572
17:15-17:30	0	73	20	93	28	196	0	224	317	0	0	0	0	178	0	74	252	252	569
17:30-17:45	0	76	9	85	20	176	0	196	281	0	0	0	0	171	0	81	252	252	533
17:45-18:00	0	91	18	109	12	108	0	120	229	0	0	0	0	132	0	60	192	192	421

Heavy Vehicle Summary Sheet - Hourly Volumes

**CARP and HWY 417 N WESTBOUND**

(ULRS Listing RR- 5 & HWY417 N)

Survey Date : Tuesday 16 June 2009

Conditions : dry

Start Time : 0700

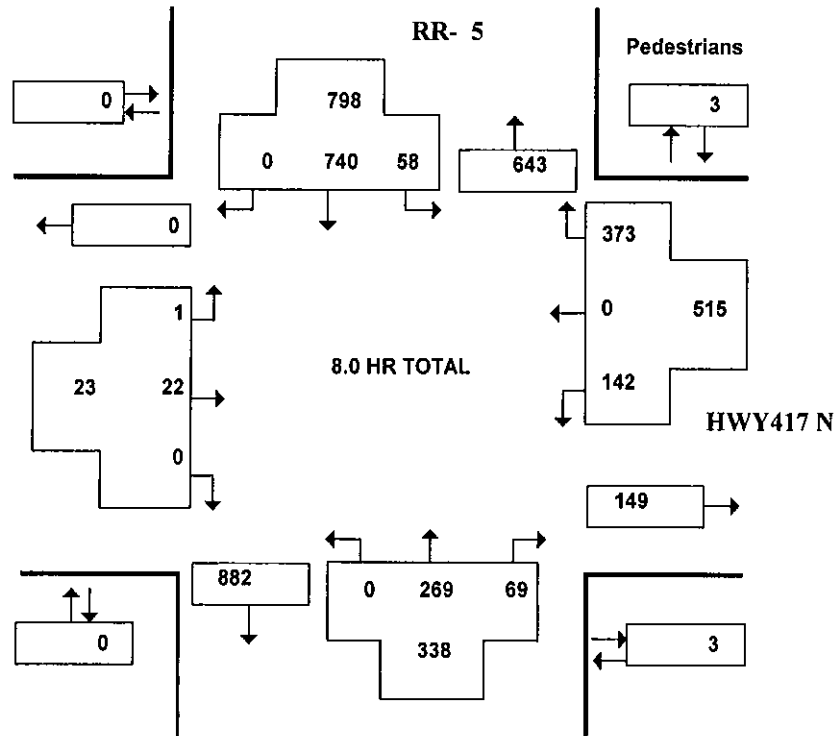

Time Period	RR- 5									HWY417 N									
	Northbound			SUB TOT	Southbound			SUB TOT	STR TOT	Eastbound			SUB TOT	Westbound			SUB TOT	STR TOT	GRAND TOT
	LT	ST	RT		LT	ST	RT			LT	ST	RT		LT	ST	RT			
07:00-08:00	0	25	1	26	7	95	0	102	128	0	0	0	0	9	0	34	43	43	171
08:00-09:00	0	36	4	40	7	140	0	147	187	0	0	0	0	31	0	59	90	90	277
09:00-10:00	0	44	9	53	6	78	0	84	137	0	0	0	0	3	0	39	42	42	179
11:30-12:30	0	18	10	28	6	73	0	79	107	1	22	0	23	11	0	38	49	72	179
12:30-13:30	0	29	11	40	5	100	0	105	145	0	0	0	0	25	0	52	77	77	222
15:00-16:00	0	38	25	63	4	101	0	105	168	0	0	0	0	25	0	66	91	91	259
16:00-17:00	0	46	6	52	14	94	0	108	160	0	0	0	0	21	0	49	70	70	230
17:00-18:00	0	33	3	36	9	59	0	68	104	0	0	0	0	17	0	36	53	53	157
<b>8.0 HR TOTAL</b>	<b>0</b>	<b>269</b>	<b>69</b>	<b>338</b>	<b>58</b>	<b>740</b>	<b>0</b>	<b>798</b>	<b>1136</b>	<b>1</b>	<b>22</b>	<b>0</b>	<b>23</b>	<b>142</b>	<b>0</b>	<b>373</b>	<b>515</b>	<b>538</b>	<b>1674</b>

Heavy Vehicles are vehicles having one rear axle with four or more wheels, or having two or more rear axles. These vehicles include most O.C. Transpo, school and inter-city buses. Further, they ARE included in the Turning Movement Count Summary.



**CARP and HWY 417 N WESTBOUND**  
(ULRS Listing RR- 5 & HWY417 N)

Survey Date: Thursday 10 July 2008  
 Conditions: dry  
 Start Time: 0700

**Total Observed U-Turns**  
 Northbound: 0 Southbound: 0  
 Eastbound: 0 Westbound: 0

**AADT Factor**  
 Thursday in July is 9

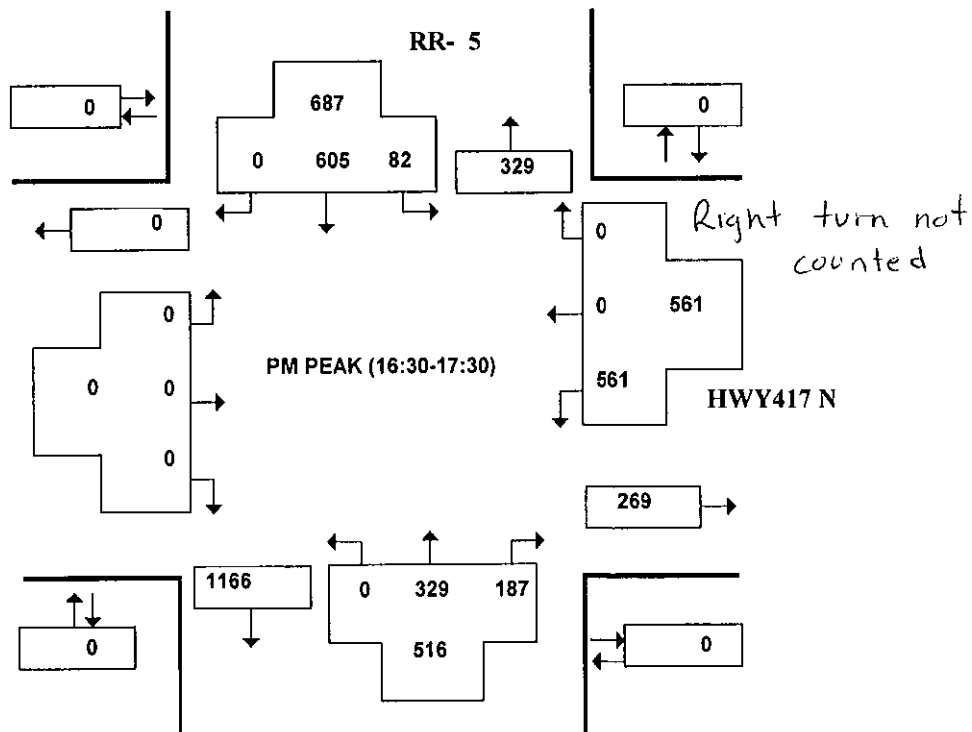
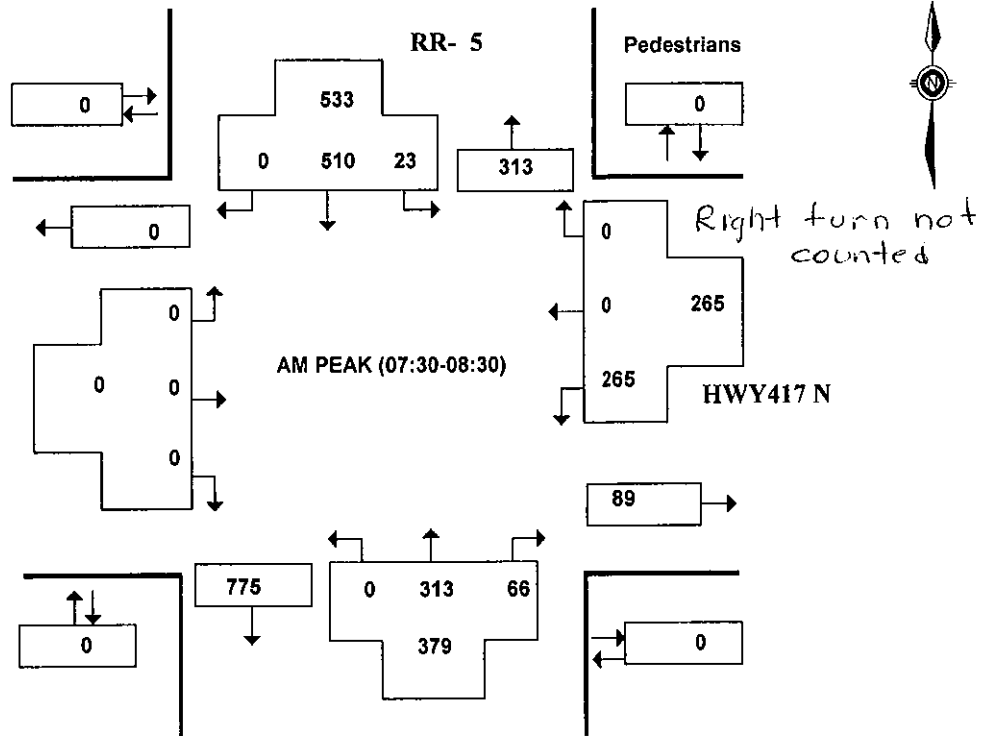

Vehicular Turning Movements - Summary

**CARP and HWY 417 N WESTBOUND**

(ULRS Listing RR- 5 & HWY417 N)

Survey Date: Thursday 10 July 2008  
 Conditions: dry  
 Start Time: 0700

Total Observed U-Turns  
 Northbound: 0 Southbound: 0  
 Eastbound: 0 Westbound: 0

AADT Factor  
 Thursday in July is  
 9

Time Period	RR- 5										HWY417 N						GRAND TOT		
	Northbound			SUB TOT	Southbound			SUB TOT	STR TOT	Eastbound			SUB TOT	Westbound				SUB TOT	STR TOT
	LT	ST	RT		LT	ST	RT			LT	ST	RT		LT	ST	RT			
07:00-08:00	0	287	62	349	21	448	0	469	818	0	0	0	0	245	0	0	245	245	1063
08:00-09:00	0	302	48	350	19	496	0	515	865	0	0	0	0	295	0	0	295	295	1160
09:00-10:00	0	194	54	248	24	446	0	470	718	0	0	0	0	237	0	0	237	237	955
11:30-12:30	0	224	60	284	17	419	0	436	720	0	0	0	0	340	0	0	340	340	1060
12:30-13:30	0	202	75	277	21	428	0	449	726	0	0	0	0	297	0	0	297	297	1023
15:00-16:00	0	251	114	365	25	458	0	483	848	0	0	0	0	463	0	0	463	463	1311
16:00-17:00	0	311	159	470	69	538	0	607	1077	0	0	0	0	556	0	0	556	556	1633
17:00-18:00	0	306	189	495	70	594	0	664	1159	0	0	0	0	547	0	0	547	547	1706
<b>8.0 HR TOTAL</b>	<b>0</b>	<b>2077</b>	<b>761</b>	<b>2838</b>	<b>266</b>	<b>3827</b>	<b>0</b>	<b>4093</b>	<b>6931</b>	<b>0</b>	<b>0</b>	<b>0</b>	<b>0</b>	<b>2980</b>	<b>0</b>	<b>0</b>	<b>2980</b>	<b>2980</b>	<b>9911</b>

Right turn not counted

EQU. 12 HR TOTAL 0 2887 1057 3944 369 5319 0 5688 9632 0 0 0 0 4142 0 0 4142 4142 13774

Note: These values are calculated by multiplying the totals by the appropriate expansion factor.

AVG. 12 HR TOTAL 0 2598 951 3549 332 4787 0 5119 8668 0 0 0 0 3727 0 0 3727 3727 12395

Note: These volumes are calculated by multiplying the Equivalent 12 hr. totals by the AADT factor.

AVG. 24 HR TOTAL 0 3403 1245 4648 434 6270 0 6704 11352 0 0 0 0 4882 0 0 4882 4882 16234

Note: These volumes were calculated by multiplying the Average Daily 12 hr totals by 1.31.

AM TOTAL (0700-0900) 0 589 110 699 40 944 0 984 1683 0 0 0 0 540 0 0 540 540 2223

PM TOTAL (1530-1730) 0 608 340 948 124 1087 0 1211 2159 0 0 0 0 1076 0 0 1076 1076 3235



Vehicular Turning Movements (15 Min. Volumes)

CARP and HWY 417 N WESTBOUND

(ULRS Listing RR- 5 & HWY417 N)

Survey Date: Thursday 10 July 2008
Conditions: dry
Start Time: 07:00

Total Observed U-Turns
Northbound: 0 Southbound: 0
Eastbound: 0 Westbound: 0

AADT Factor
Thursday in July is 9

Table with columns: Time Period, RR-5 (Northbound, Southbound), HWY417 N (Eastbound, Westbound), SUB TOT, STR TOT, GRAND TOT. Includes handwritten note: 'Right turn not counted' with an arrow pointing to the RT column under HWY417 N Westbound.



Heavy Vehicle Summary Sheet - Hourly Volumes

**CARP and HWY 417 N WESTBOUND**

(ULRS Listing RR- 5 & HWY417 N)

Survey Date :Thursday 10 July 2008

Conditions : dry

Start Time : 0700

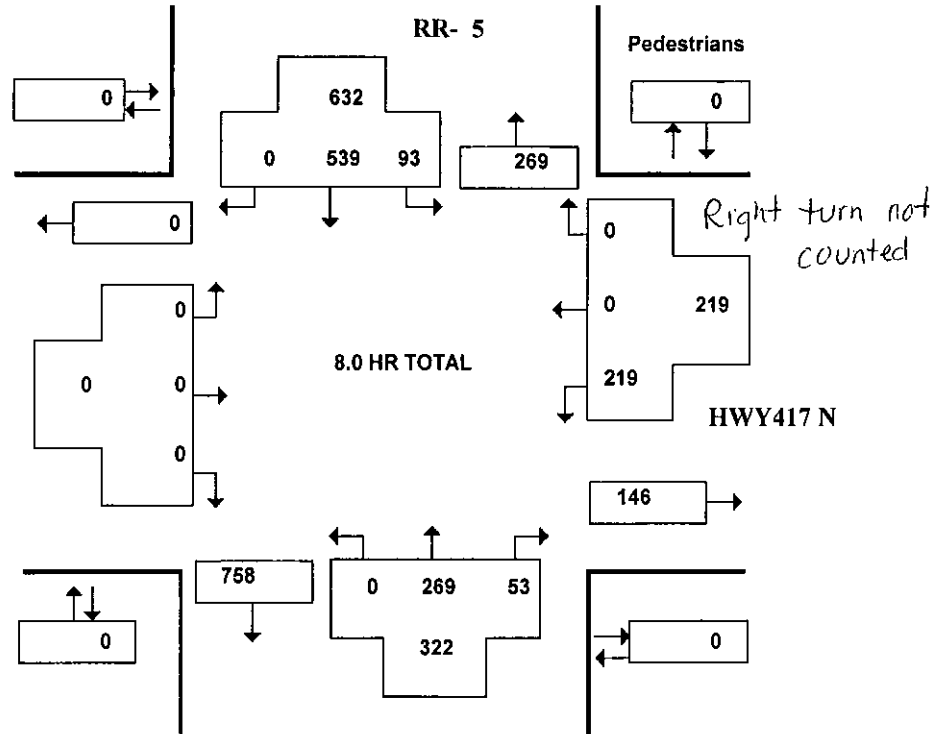

Time Period	RR- 5										HWY417 N								
	Northbound			SUB TOT	Southbound			SUB TOT	STR TOT	Eastbound			SUB TOT	Westbound			SUB TOT	STR TOT	GRAND TOT
	LT	ST	RT		LT	ST	RT			LT	ST	RT		LT	ST	RT			
07:00-08:00	0	25	7	32	11	68	0	79	111	0	0	0	0	31	0	0	31	31	142
08:00-09:00	0	36	5	41	9	80	0	89	130	0	0	0	0	27	0	0	27	27	157
09:00-10:00	0	21	13	34	12	67	0	79	113	0	0	0	0	30	0	0	30	30	143
11:30-12:30	0	41	1	42	8	86	0	94	136	0	0	0	0	39	0	0	39	39	175
12:30-13:30	0	29	16	45	11	63	0	74	119	0	0	0	0	21	0	0	21	21	140
15:00-16:00	0	34	6	40	10	64	0	74	114	0	0	0	0	31	0	0	31	31	145
16:00-17:00	0	44	3	47	15	57	0	72	119	0	0	0	0	21	0	0	21	21	140
17:00-18:00	0	39	2	41	17	54	0	71	112	0	0	0	0	19	0	0	19	19	131
<b>8.0 HR TOTAL</b>	<b>0</b>	<b>269</b>	<b>53</b>	<b>322</b>	<b>93</b>	<b>539</b>	<b>0</b>	<b>632</b>	<b>954</b>	<b>0</b>	<b>0</b>	<b>0</b>	<b>0</b>	<b>219</b>	<b>0</b>	<b>0</b>	<b>219</b>	<b>219</b>	<b>1173</b>

Heavy Vehicles are vehicles having one rear axle with four or more wheels, or having two or more rear axles. These vehicles include most O.C. Transpo, school and inter-city buses. Further, they ARE included in the Turning Movement Count Summary.

**CARP and HWY 417 N WESTBOUND**  
(ULRS Listing RR- 5 & HWY417 N)

**Survey Date:** Thursday 22 June 2006  
**Conditions:** DRY  
**Start Time:** 0700

**Total Observed U-Turns**  
Northbound: 0 Southbound: 0  
Eastbound: 0 Westbound: 2

**AADT Factor**  
Thursday in June is 9

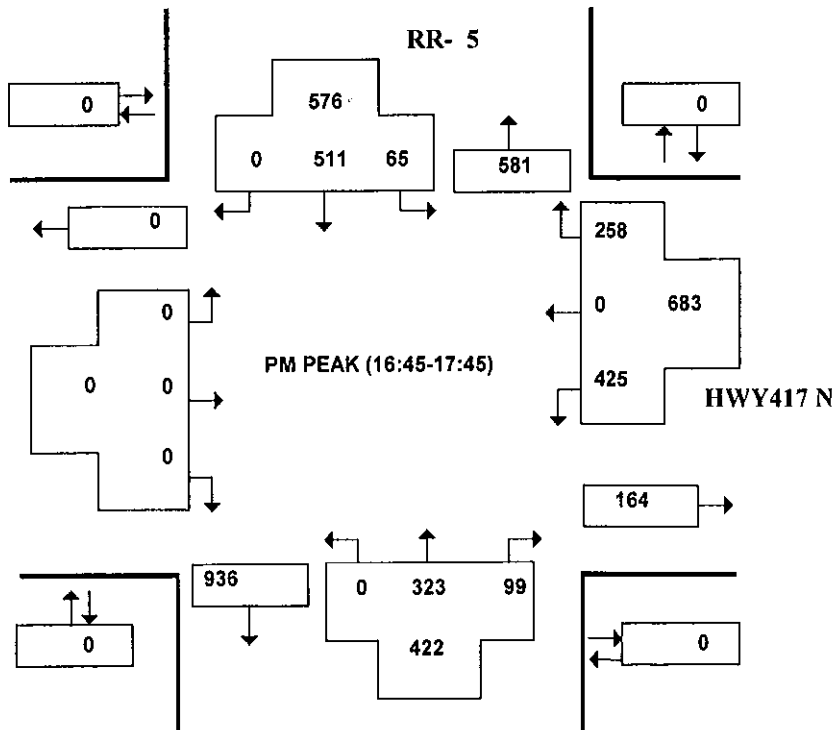
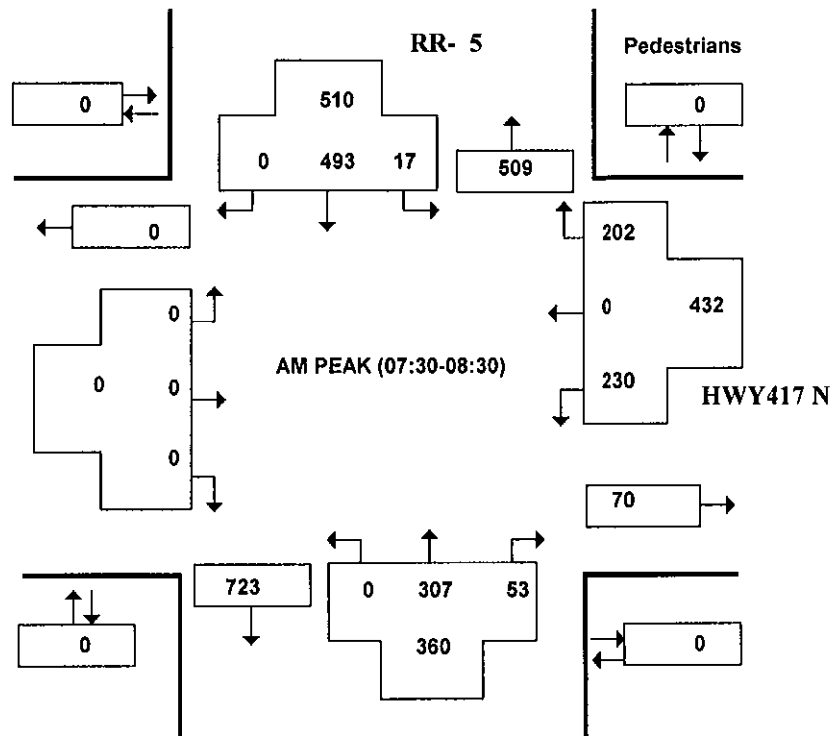

Vehicular Turning Movements - Summary

**CARP and HWY 417 N WESTBOUND**

(ULRS Listing RR- 5 & HWY417 N)

Survey Date: Thursday 22 June 2006  
 Conditions: DRY  
 Start Time: 0700

**Total Observed U-Turns**  
 Northbound: 0 Southbound: 0  
 Eastbound: 0 Westbound: 2

**AADT Factor**  
 Thursday in June is  
 9

Time Period	RR- 5										HWY417 N									
	Northbound			SUB TOT	Southbound			SUB TOT	STR TOT	Eastbound			SUB TOT	Westbound			SUB TOT	STR TOT	GRAND TOT	
	LT	ST	RT		LT	ST	RT			LT	ST	RT		LT	ST	RT				
07:00-08:00	0	276	46	322	19	457	0	476	798	0	0	0	0	214	0	224	438	438	1236	
08:00-09:00	0	260	52	312	18	470	0	488	800	0	0	0	0	177	0	171	348	348	1148	
09:00-10:00	0	196	24	220	21	415	0	436	656	0	0	0	0	122	0	169	291	291	947	
11:30-12:30	0	221	37	258	23	364	0	387	645	0	0	0	0	178	0	165	343	343	988	
12:30-13:30	0	224	29	253	17	400	0	417	670	0	0	0	0	210	0	168	378	378	1048	
15:00-16:00	0	265	69	334	14	300	0	314	648	0	0	0	0	259	0	246	505	505	1153	
16:00-17:00	0	304	88	392	62	499	0	561	953	0	0	0	0	323	0	279	602	602	1555	
17:00-18:00	0	285	97	382	54	480	0	534	916	0	0	0	0	395	0	245	640	640	1556	
<b>8.0 HR TOTAL</b>	0	2031	442	2473	228	3385	0	3613	6086	0	0	0	0	1878	0	1667	3545	3545	9631	

EQU. 12 HR TOTAL 0 2823 614 3437 316 4705 0 5021 8458 0 0 0 0 2610 0 2317 4927 4927 13385

Note: These values are calculated by multiplying the totals by the appropriate expansion factor.

AVG. 12 HR TOTAL 0 2540 552 3092 284 4234 0 4518 7610 0 0 0 0 2349 0 2085 4434 4434 12044

Note: These volumes are calculated by multiplying the Equivalent 12 hr. totals by the AADT factor.

AVG. 24 HR TOTAL 0 3327 723 4050 372 5546 0 5918 9968 0 0 0 0 3077 0 2731 5808 5808 15776

Note: These volumes were calculated by multiplying the Average Daily 12 hr totals by 1.31.

AM TOTAL (0700-0900) 0 536 98 634 37 927 0 964 1598 0 0 0 0 391 0 395 786 786 2384

PM TOTAL (1530-1730) 0 636 182 818 103 927 0 1030 1848 0 0 0 0 642 0 569 1211 1211 3059

Vehicular Turning Movements (15 Min. Volumes)

**CARP and HWY 417 N WESTBOUND**  
(ULRS Listing RR- 5 & HWY417 N)

Survey Date: Thursday 22 June 2006  
 Conditions: DRY  
 Start Time: 07:00

**Total Observed U-Turns**  
 Northbound: 0 Southbound: 0  
 Eastbound: 0 Westbound: 2

**AADT Factor**  
 Thursday in June is  
 9

Time Period	RR- 5									HWY417 N									GRAND TOT
	Northbound			SUB TOT	Southbound			SUB TOT	STR TOT	Eastbound			SUB TOT	Westbound			SUB TOT	STR TOT	
	LT	ST	RT		LT	ST	RT			LT	ST	RT		LT	ST	RT			
07:00-07:15	0	51	7	58	3	98	0	101	159	0	0	0	0	32	0	56	88	88	247
07:15-07:30	0	66	12	78	5	108	0	113	191	0	0	0	0	57	0	55	112	112	303
07:30-07:45	0	71	14	85	7	112	0	119	204	0	0	0	0	56	0	56	112	112	316
07:45-08:00	0	88	13	101	4	139	0	143	244	0	0	0	0	69	0	57	126	126	370
08:00-08:15	0	64	15	79	4	114	0	118	197	0	0	0	0	58	0	41	99	99	296
08:15-08:30	0	84	11	95	2	128	0	130	225	0	0	0	0	47	0	48	95	95	320
08:30-08:45	0	62	16	78	6	111	0	117	195	0	0	0	0	46	0	38	84	84	279
08:45-09:00	0	50	10	60	6	117	0	123	183	0	0	0	0	26	0	44	70	70	253
09:00-09:15	0	54	10	64	8	98	0	106	170	0	0	0	0	26	0	40	66	66	236
09:15-09:30	0	67	5	72	4	119	0	123	195	0	0	0	0	34	0	39	73	73	268
09:30-09:45	0	41	5	46	7	108	0	115	161	0	0	0	0	29	0	44	73	73	234
09:45-10:00	0	34	4	38	2	90	0	92	130	0	0	0	0	33	0	46	79	79	209
11:30-11:45	0	49	6	55	3	83	0	86	141	0	0	0	0	28	0	36	64	64	205
11:45-12:00	0	58	12	70	8	93	0	101	171	0	0	0	0	39	0	30	69	69	240
12:00-12:15	0	54	7	61	4	112	0	116	177	0	0	0	0	42	0	44	86	86	263
12:15-12:30	0	60	12	72	8	76	0	84	156	0	0	0	0	69	0	55	124	124	280
12:30-12:45	0	53	5	58	4	93	0	97	155	0	0	0	0	52	0	43	95	95	250
12:45-13:00	0	50	8	58	5	95	0	100	158	0	0	0	0	75	0	51	126	126	284
13:00-13:15	0	59	7	66	4	87	0	91	157	0	0	0	0	45	0	39	84	84	241
13:15-13:30	0	62	9	71	4	125	0	129	200	0	0	0	0	38	0	35	73	73	273
15:00-15:15	0	47	14	61	2	43	0	45	106	0	0	0	0	34	0	33	67	67	173
15:15-15:30	0	51	22	73	6	82	0	88	161	0	0	0	0	86	0	60	146	146	307
15:30-15:45	0	69	25	94	6	82	0	88	182	0	0	0	0	88	0	88	176	176	358
15:45-16:00	0	98	8	106	0	93	0	93	199	0	0	0	0	51	0	65	116	116	315
16:00-16:15	0	82	26	108	7	129	0	136	244	0	0	0	0	57	0	79	136	136	380
16:15-16:30	0	83	22	105	4	111	0	115	220	0	0	0	0	73	0	69	142	142	362
16:30-16:45	0	62	19	81	33	119	0	152	233	0	0	0	0	86	0	74	160	160	393
16:45-17:00	0	77	21	98	18	140	0	158	256	0	0	0	0	107	0	57	164	164	420
17:00-17:15	0	84	26	110	12	121	0	133	243	0	0	0	0	80	0	67	147	147	390
17:15-17:30	0	81	35	116	23	132	0	155	271	0	0	0	0	100	0	70	170	170	441
17:30-17:45	0	81	17	98	12	118	0	130	228	0	0	0	0	138	0	64	202	202	430
17:45-18:00	0	39	19	58	7	109	0	116	174	0	0	0	0	77	0	44	121	121	295



Heavy Vehicle Summary Sheet - Hourly Volumes

**CARP and HWY 417 N WESTBOUND**

(ULRS Listing RR- 5 & HWY417 N)

Survey Date : Thursday 22 June 2006

Conditions : DRY

Start Time : 0700

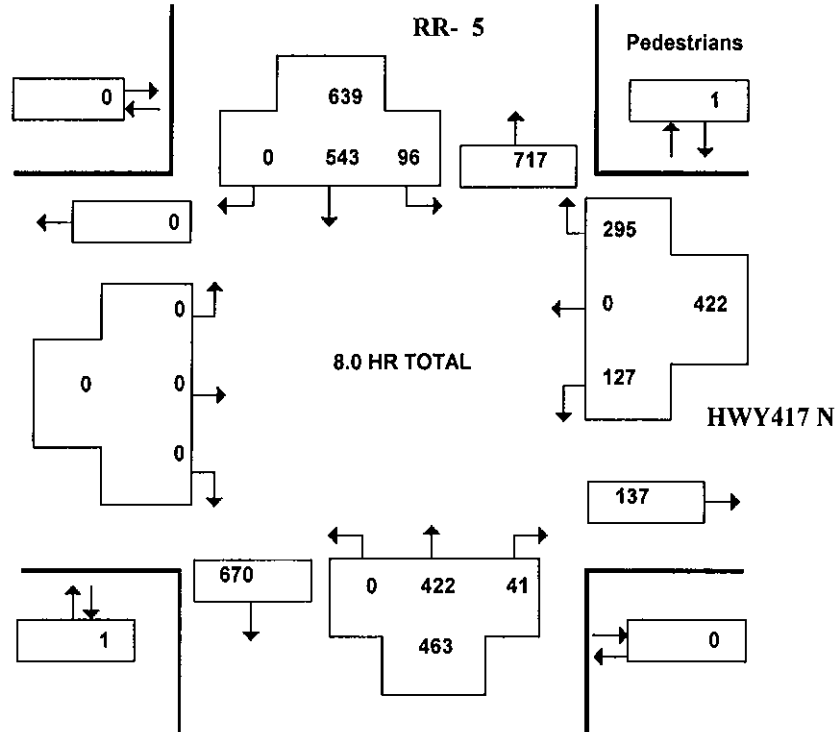

Time Period	RR- 5									HWY417 N									
	Northbound			SUB	Southbound			SUB	STR	Eastbound			SUB	Westbound			SUB	STR	GRAND
	LT	ST	RT	TOT	LT	ST	RT	TOT	TOT	LT	ST	RT	TOT	LT	ST	RT	TOT	TOT	TOT
07:00-08:00	0	51	5	56	14	85	0	99	155	0	0	0	0	23	0	39	62	62	217
08:00-09:00	0	42	8	50	15	80	0	95	145	0	0	0	0	17	0	25	42	42	187
09:00-10:00	0	53	4	57	13	80	0	93	150	0	0	0	0	15	0	34	49	49	199
11:30-12:30	0	51	9	60	10	62	0	72	132	0	0	0	0	15	0	42	57	57	189
12:30-13:30	0	57	3	60	11	72	0	83	143	0	0	0	0	14	0	47	61	61	204
15:00-16:00	0	64	1	65	6	58	0	64	129	0	0	0	0	18	0	41	59	59	188
16:00-17:00	0	75	4	79	14	78	0	92	171	0	0	0	0	12	0	45	57	57	228
17:00-18:00	0	29	7	36	13	28	0	41	77	0	0	0	0	13	0	22	35	35	112
<b>8.0 HR TOTAL</b>	<b>0</b>	<b>422</b>	<b>41</b>	<b>463</b>	<b>96</b>	<b>543</b>	<b>0</b>	<b>639</b>	<b>1102</b>	<b>0</b>	<b>0</b>	<b>0</b>	<b>0</b>	<b>127</b>	<b>0</b>	<b>295</b>	<b>422</b>	<b>422</b>	<b>1524</b>

Heavy Vehicles are vehicles having one rear axle with four or more wheels, or having two or more rear axles. These vehicles include most O.C. Transpo, school and inter-city buses. Further, they ARE included in the Turning Movement Count Summary.







Vehicular Turning Movements - Summary

**CARP and HWY 417 N WESTBOUND**

(ULRS Listing RR- 5 & HWY417 N)

Survey Date: Wednesday 13 July 2005  
 Conditions: DRY  
 Start Time: 0700

Total Observed U-Turns  
 Northbound: 0 Southbound: 0  
 Eastbound: 0 Westbound: 0

AADT Factor  
 Wednesday in July is  
 9

Time Period	RR- 5									HWY417 N									
	Northbound			SUB TOT	Southbound			SUB TOT	STR TOT	Eastbound			SUB TOT	Westbound			SUB TOT	STR TOT	GRAND TOT
	LT	ST	RT		LT	ST	RT			LT	ST	RT		LT	ST	RT			
07:00-08:00	0	231	39	270	37	544	0	581	851	0	0	0	0	229	0	189	418	418	1269
08:00-09:00	0	256	33	289	24	543	0	567	856	0	0	0	0	317	0	168	485	485	1341
09:00-10:00	0	225	34	259	39	418	0	457	716	0	0	0	0	281	0	153	434	434	1150
11:30-12:30	0	237	37	274	42	425	0	467	741	0	0	0	0	296	0	126	422	422	1163
12:30-13:30	0	243	26	269	26	449	0	475	744	0	0	0	0	259	0	145	404	404	1148
15:00-16:00	0	286	74	360	53	466	0	519	879	0	0	0	0	476	0	176	652	652	1531
16:00-17:00	0	299	99	398	98	656	0	754	1152	0	0	0	0	625	0	210	835	835	1987
17:00-18:00	0	227	98	325	83	491	0	574	899	0	0	0	0	738	0	208	946	946	1845
<b>8.0 HR TOTAL</b>	<b>0</b>	<b>2004</b>	<b>440</b>	<b>2444</b>	<b>402</b>	<b>3992</b>	<b>0</b>	<b>4394</b>	<b>6838</b>	<b>0</b>	<b>0</b>	<b>0</b>	<b>0</b>	<b>3221</b>	<b>0</b>	<b>1375</b>	<b>4596</b>	<b>4596</b>	<b>11434</b>

EQU. 12 HR TOTAL 0 2785 611 3396 558 5548 0 6106 9502 0 0 0 0 04477 0 1911 6388 6388 15890

Note: These values are calculated by multiplying the totals by the appropriate expansion factor.

AVG. 12 HR TOTAL 0 2506 549 3055 502 4993 0 5495 8550 0 0 0 0 0 4029 0 1719 5748 5748 14298

Note: These volumes are calculated by multiplying the Equivalent 12 hr. totals by the AADT factor.

AVG. 24 HR TOTAL 0 3282 719 4001 657 6540 0 7197 11198 0 0 0 0 0 5277 0 2251 7528 7528 18726

Note: These volumes were calculated by multiplying the Average Daily 12 hr totals by 1.31.

AM TOTAL (0700-0900) 0 487 72 559 61 1087 0 1148 1707 0 0 0 0 0 546 0 357 903 903 2610

PM TOTAL (1530-1730) 0 577 204 781 176 1143 0 1319 2100 0 0 0 0 0 1317 0 433 1750 1750 3850



Vehicular Turning Movements (15 Min. Volumes)

**CARP and HWY 417 N WESTBOUND**  
(ULRS Listing RR- 5 & HWY417 N)

Survey Date: Wednesday 13 July 2005  
 Conditions: DRY  
 Start Time: 07:00

Total Observed U-Turns  
 Northbound: 0 Southbound: 0  
 Eastbound: 0 Westbound: 0

AADT Factor  
 Wednesday in July is  
 9

Time Period	RR- 5									HWY417 N									
	Northbound			SUB TOT	Southbound			SUB TOT	STR TOT	Eastbound			SUB TOT	Westbound			SUB TOT	STR TOT	GRAND TOT
	LT	ST	RT		LT	ST	RT			LT	ST	RT		LT	ST	RT			
07:00-07:15	0	38	6	44	6	107	0	113	157	0	0	0	0	48	0	33	81	81	238
07:15-07:30	0	59	19	78	8	116	0	124	202	0	0	0	0	62	0	51	113	113	315
07:30-07:45	0	63	7	70	8	159	0	167	237	0	0	0	0	63	0	47	110	110	347
07:45-08:00	0	71	7	78	15	162	0	177	255	0	0	0	0	56	0	58	114	114	369
08:00-08:15	0	55	8	63	8	134	0	142	205	0	0	0	0	70	0	53	123	123	328
08:15-08:30	0	71	8	79	7	162	0	169	248	0	0	0	0	98	0	35	133	133	381
08:30-08:45	0	71	12	83	4	134	0	138	221	0	0	0	0	92	0	49	141	141	362
08:45-09:00	0	59	5	64	5	113	0	118	182	0	0	0	0	57	0	31	88	88	270
09:00-09:15	0	62	15	77	12	104	0	116	193	0	0	0	0	77	0	39	116	116	309
09:15-09:30	0	48	4	52	14	101	0	115	167	0	0	0	0	79	0	38	117	117	284
09:30-09:45	0	38	12	50	5	117	0	122	172	0	0	0	0	77	0	41	118	118	290
09:45-10:00	0	77	3	80	8	96	0	104	184	0	0	0	0	48	0	35	83	83	267
11:30-11:45	0	50	7	57	11	112	0	123	180	0	0	0	0	54	0	30	84	84	264
11:45-12:00	0	63	10	73	13	98	0	111	184	0	0	0	0	90	0	29	119	119	303
12:00-12:15	0	58	8	66	14	118	0	132	198	0	0	0	0	57	0	34	91	91	289
12:15-12:30	0	66	12	78	4	97	0	101	179	0	0	0	0	95	0	33	128	128	307
12:30-12:45	0	62	6	68	6	119	0	125	193	0	0	0	0	72	0	35	107	107	300
12:45-13:00	0	58	1	59	5	117	0	122	181	0	0	0	0	60	0	30	90	90	271
13:00-13:15	0	62	9	71	5	83	0	88	159	0	0	0	0	74	0	40	114	114	273
13:15-13:30	0	61	10	71	10	130	0	140	211	0	0	0	0	53	0	40	93	93	304
15:00-15:15	0	68	15	83	13	130	0	143	226	0	0	0	0	101	0	30	131	131	357
15:15-15:30	0	74	18	92	10	100	0	110	202	0	0	0	0	118	0	50	168	168	370
15:30-15:45	0	60	21	81	20	126	0	146	227	0	0	0	0	120	0	41	161	161	388
15:45-16:00	0	84	20	104	10	110	0	120	224	0	0	0	0	137	0	55	192	192	416
16:00-16:15	0	69	15	84	21	144	0	165	249	0	0	0	0	124	0	32	156	156	405
16:15-16:30	0	65	19	84	13	146	0	159	243	0	0	0	0	152	0	62	214	214	457
16:30-16:45	0	82	38	120	45	191	0	236	356	0	0	0	0	163	0	53	216	216	572
16:45-17:00	0	83	27	110	19	175	0	194	304	0	0	0	0	186	0	63	249	249	553
17:00-17:15	0	79	31	110	16	154	0	170	280	0	0	0	0	208	0	55	263	263	543
17:15-17:30	0	55	33	88	32	97	0	129	217	0	0	0	0	227	0	72	299	299	516
17:30-17:45	0	54	17	71	16	124	0	140	211	0	0	0	0	161	0	50	211	211	422
17:45-18:00	0	39	17	56	19	116	0	135	191	0	0	0	0	142	0	31	173	173	364

Heavy Vehicle Summary Sheet - Hourly Volumes

**CARP and HWY 417 N WESTBOUND**

(ULRS Listing RR- 5 & HWY417 N)

Survey Date : Wednesday 13 July 2005

Conditions : DRY

Start Time : 0700

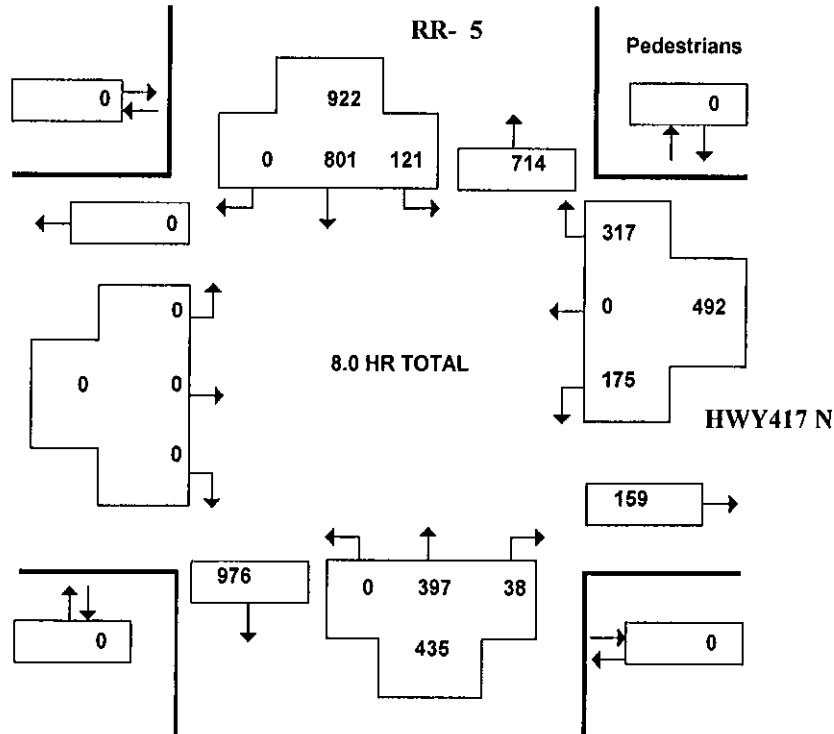

Time Period	RR- 5									HWY417 N									
	Northbound			SUB TOT	Southbound			SUB TOT	STR TOT	Eastbound			SUB TOT	Westbound			SUB TOT	STR TOT	GRAND TOT
	LT	ST	RT		LT	ST	RT			LT	ST	RT		LT	ST	RT			
07:00-08:00	0	47	4	51	22	130	0	152	203	0	0	0	0	18	0	41	59	59	262
08:00-09:00	0	51	3	54	16	116	0	132	186	0	0	0	0	20	0	40	60	60	246
09:00-10:00	0	58	7	65	15	115	0	130	195	0	0	0	0	36	0	43	79	79	274
11:30-12:30	0	44	3	47	19	90	0	109	156	0	0	0	0	26	0	38	64	64	220
12:30-13:30	0	41	6	47	14	110	0	124	171	0	0	0	0	19	0	38	57	57	228
15:00-16:00	0	70	10	80	5	99	0	104	184	0	0	0	0	19	0	48	67	67	251
16:00-17:00	0	55	2	57	22	93	0	115	172	0	0	0	0	14	0	43	57	57	229
17:00-18:00	0	31	3	34	8	48	0	56	90	0	0	0	0	23	0	26	49	49	139
<b>8.0 HR TOTAL</b>	<b>0</b>	<b>397</b>	<b>38</b>	<b>435</b>	<b>121</b>	<b>801</b>	<b>0</b>	<b>922</b>	<b>1357</b>	<b>0</b>	<b>0</b>	<b>0</b>	<b>0</b>	<b>175</b>	<b>0</b>	<b>317</b>	<b>492</b>	<b>492</b>	<b>1849</b>

Heavy Vehicles are vehicles having one rear axle with four or more wheels, or having two or more rear axles. These vehicles include most O.C. Transpo, school and inter-city buses. Further, they ARE included in the Turning Movement Count Summary.

**CARP and HWY 417 N WESTBOUND**  
(ULRS Listing RR- 5 & HWY417 N)

**Survey Date:** Friday 3 August 2001  
**Conditions:** Dry  
**Start Time:** 0700

**Total Observed U-Turns**  
Northbound: 0 Southbound: 0  
Eastbound: 0 Westbound: 0

**AADT Factor**  
Friday in August is  
9

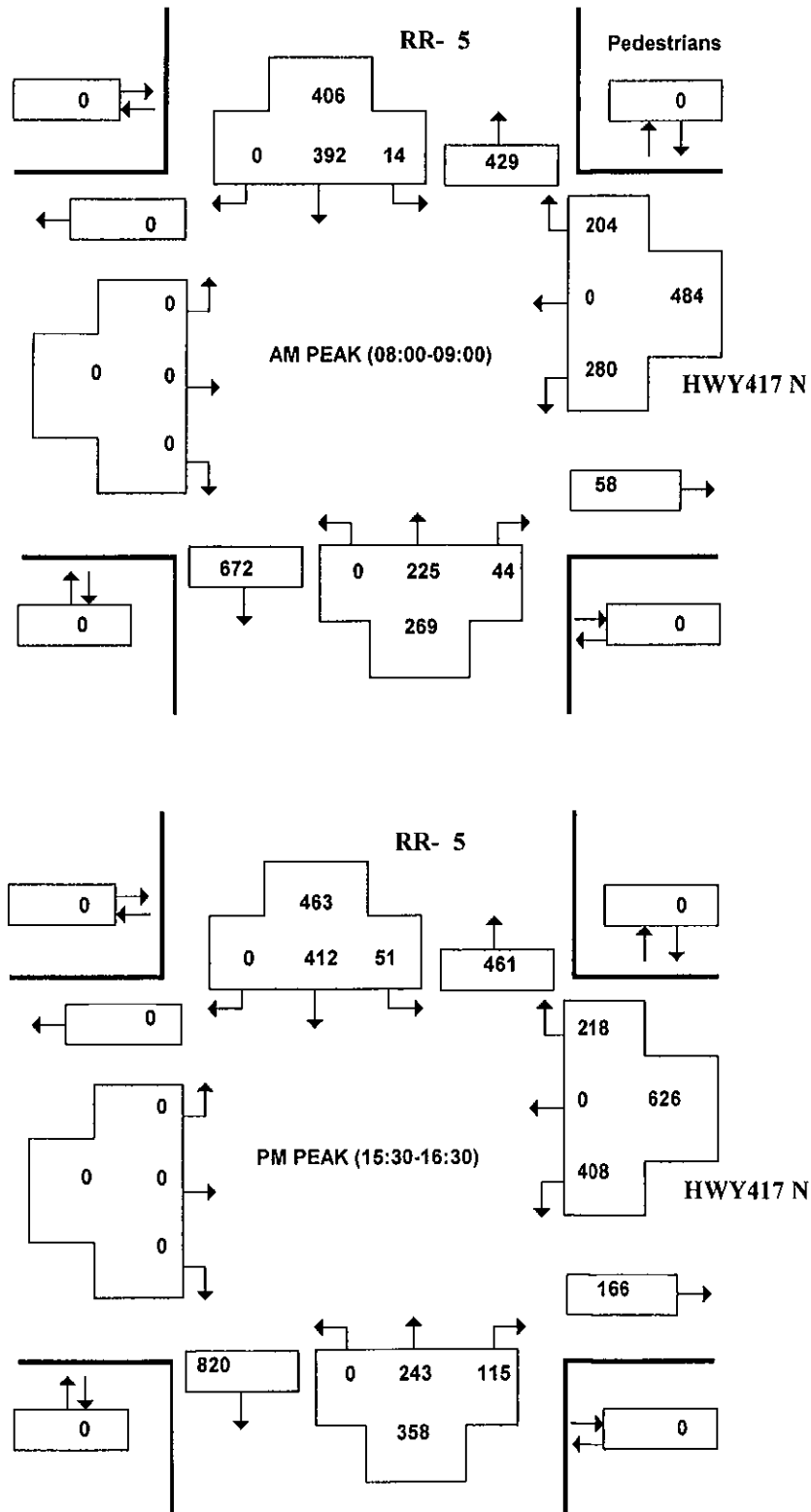



Vehicular Turning Movements - Summary

**CARP and HWY 417 N WESTBOUND**

(ULRS Listing RR- 5 & HWY417 N)

Survey Date: Friday 3 August 2001  
 Conditions: Dry  
 Start Time: 0700

**Total Observed U-Turns**  
 Northbound: 0 Southbound: 0  
 Eastbound: 0 Westbound: 0

**AADT Factor**  
 Friday in August is  
 9

Time Period	RR- 5									HWY417 N									
	Northbound			SUB TOT	Southbound			SUB TOT	STR TOT	Eastbound			SUB TOT	Westbound			SUB TOT	STR TOT	GRAND TOT
	LT	ST	RT		LT	ST	RT			LT	ST	RT		LT	ST	RT			
07:00-08:00	0	216	32	248	14	375	0	389	637	0	0	0	0	208	0	198	406	406	1043
08:00-09:00	0	225	44	269	14	392	0	406	675	0	0	0	0	280	0	204	484	484	1159
09:00-10:00	0	168	63	231	20	349	0	369	600	0	0	0	0	231	0	154	385	385	985
11:30-12:30	0	223	74	297	28	426	0	454	751	0	0	0	0	321	0	185	506	506	1257
12:30-13:30	0	231	76	307	29	388	0	417	724	0	0	0	0	325	0	210	535	535	1259
15:00-16:00	0	231	108	339	48	419	0	467	806	0	0	0	0	359	0	210	569	569	1375
16:00-17:00	0	218	134	352	32	349	0	381	733	0	0	0	0	407	0	208	615	615	1348
17:00-18:00	0	156	121	277	35	328	0	363	640	0	0	0	0	367	0	220	587	587	1227
<b>8.0 HR TOTAL</b>	0	1668	652	2320	220	3026	0	3246	5566	0	0	0	0	2498	0	1589	4087	4087	9653
<b>EQU. 12 HR TOTAL</b>	0	2318	906	3224	305	4206	0	4511	7735	0	0	0	0	3472	0	2208	5680	5680	13415
Note: These values are calculated by multiplying the totals by the appropriate expansion factor.																			
<b>AVG. 12 HR TOTAL</b>	0	2086	815	2901	274	3785	0	4059	6960	0	0	0	0	3124	0	1987	5111	5111	12071
Note: These volumes are calculated by multiplying the Equivalent 12 hr. totals by the AADT factor.																			
<b>AVG. 24 HR TOTAL</b>	0	2732	1067	3799	358	4958	0	5316	9115	0	0	0	0	4092	0	2602	6694	6694	15809
Note: These volumes were calculated by multiplying the Average Daily 12 hr totals by 1.31.																			
<b>AM TOTAL (0700-0900)</b>	0	441	76	517	28	767	0	795	1312	0	0	0	0	488	0	402	890	890	2202
<b>PM TOTAL (1530-1730)</b>	0	429	256	685	86	760	0	846	1531	0	0	0	0	796	0	448	1244	1244	2775



Vehicular Turning Movements (15 Min. Volumes)

**CARP and HWY 417 N WESTBOUND**

(ULRS Listing RR- 5 & HWY417 N)

Survey Date: Friday 3 August 2001  
 Conditions: Dry  
 Start Time: 07:00

**Total Observed U-Turns**  
 Northbound: 0 Southbound: 0  
 Eastbound: 0 Westbound: 0

**AADT Factor**  
 Friday in August is  
 9

Time Period	RR- 5									HWY417 N									GRAND TOT
	Northbound			SUB TOT	Southbound			SUB TOT	STR TOT	Eastbound			SUB TOT	Westbound			SUB TOT	STR TOT	
	LT	ST	RT		LT	ST	RT			LT	ST	RT		LT	ST	RT			
07:00-07:15	0	53	4	57	1	91	0	92	149	0	0	0	0	49	0	47	96	96	245
07:15-07:30	0	37	13	50	4	85	0	89	139	0	0	0	0	43	0	58	101	101	240
07:30-07:45	0	55	11	66	5	97	0	102	168	0	0	0	0	53	0	45	98	98	266
07:45-08:00	0	71	4	75	4	102	0	106	181	0	0	0	0	63	0	48	111	111	292
08:00-08:15	0	61	10	71	2	90	0	92	163	0	0	0	0	63	0	49	112	112	275
08:15-08:30	0	50	11	61	2	110	0	112	173	0	0	0	0	67	0	59	126	126	299
08:30-08:45	0	54	8	62	0	87	0	87	149	0	0	0	0	74	0	52	126	126	275
08:45-09:00	0	60	15	75	10	105	0	115	190	0	0	0	0	76	0	44	120	120	310
09:00-09:15	0	41	25	66	7	82	0	89	155	0	0	0	0	64	0	30	94	94	249
09:15-09:30	0	41	14	55	5	76	0	81	136	0	0	0	0	47	0	35	82	82	218
09:30-09:45	0	46	8	54	1	89	0	90	144	0	0	0	0	64	0	42	106	106	250
09:45-10:00	0	40	16	56	7	102	0	109	165	0	0	0	0	56	0	47	103	103	268
11:30-11:45	0	50	10	60	6	97	0	103	163	0	0	0	0	70	0	46	116	116	279
11:45-12:00	0	49	26	75	5	111	0	116	191	0	0	0	0	83	0	55	138	138	329
12:00-12:15	0	63	14	77	13	113	0	126	203	0	0	0	0	86	0	45	131	131	334
12:15-12:30	0	61	24	85	4	105	0	109	194	0	0	0	0	82	0	39	121	121	315
12:30-12:45	0	59	14	73	9	92	0	101	174	0	0	0	0	77	0	47	124	124	298
12:45-13:00	0	55	21	76	8	95	0	103	179	0	0	0	0	104	0	55	159	159	338
13:00-13:15	0	58	20	78	4	112	0	116	194	0	0	0	0	70	0	56	126	126	320
13:15-13:30	0	59	21	80	8	89	0	97	177	0	0	0	0	74	0	52	126	126	303
15:00-15:15	0	54	27	81	10	93	0	103	184	0	0	0	0	74	0	46	120	120	304
15:15-15:30	0	56	22	78	9	107	0	116	194	0	0	0	0	85	0	53	138	138	332
15:30-15:45	0	66	31	97	17	131	0	148	245	0	0	0	0	101	0	68	169	169	414
15:45-16:00	0	55	28	83	12	88	0	100	183	0	0	0	0	99	0	43	142	142	325
16:00-16:15	0	63	28	91	15	92	0	107	198	0	0	0	0	107	0	57	164	164	362
16:15-16:30	0	59	28	87	7	101	0	108	195	0	0	0	0	101	0	50	151	151	346
16:30-16:45	0	49	37	86	6	84	0	90	176	0	0	0	0	92	0	56	148	148	324
16:45-17:00	0	47	41	88	4	72	0	76	164	0	0	0	0	107	0	45	152	152	316
17:00-17:15	0	38	40	78	10	100	0	110	188	0	0	0	0	96	0	60	156	156	344
17:15-17:30	0	52	23	75	15	92	0	107	182	0	0	0	0	93	0	69	162	162	344
17:30-17:45	0	34	30	64	8	71	0	79	143	0	0	0	0	99	0	43	142	142	285
17:45-18:00	0	32	28	60	2	65	0	67	127	0	0	0	0	79	0	48	127	127	254

Heavy Vehicle Summary Sheet - Hourly Volumes

**CARP and HWY 417 N WESTBOUND**

(ULRS Listing RR- 5 & HWY417 N)

Survey Date : Friday 3 August 2001

Conditions : Dry

Start Time : 0700

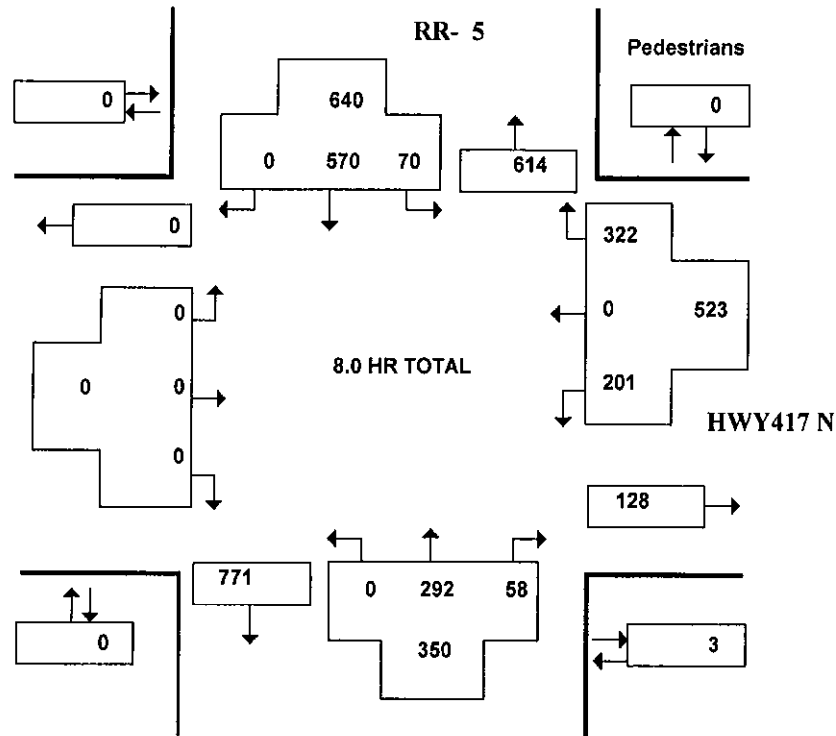

Time Period	RR- 5					HWY417 N													
	Northbound			SUB	Southbound			SUB	STR	Eastbound			SUB	Westbound			SUB	STR	GRAND
	LT	ST	RT	TOT	LT	ST	RT	TOT	TOT	LT	ST	RT	TOT	LT	ST	RT	TOT	TOT	TOT
07:00-08:00	0	31	2	33	13	85	0	98	131	0	0	0	0	20	0	31	51	51	182
08:00-09:00	0	50	7	57	8	79	0	87	144	0	0	0	0	28	0	41	69	69	213
09:00-10:00	0	44	10	54	11	83	0	94	148	0	0	0	0	35	0	45	80	80	228
11:30-12:30	0	48	8	56	8	89	0	97	153	0	0	0	0	34	0	47	81	81	234
12:30-13:30	0	55	7	62	12	97	0	109	171	0	0	0	0	23	0	59	82	82	253
15:00-16:00	0	34	7	41	10	62	0	72	113	0	0	0	0	24	0	57	81	81	194
16:00-17:00	0	23	8	31	5	47	0	52	83	0	0	0	0	12	0	22	34	34	117
17:00-18:00	0	7	9	16	3	28	0	31	47	0	0	0	0	25	0	20	45	45	92
<b>8.0 HR TOTAL</b>	<b>0</b>	<b>292</b>	<b>58</b>	<b>350</b>	<b>70</b>	<b>570</b>	<b>0</b>	<b>640</b>	<b>990</b>	<b>0</b>	<b>0</b>	<b>0</b>	<b>0</b>	<b>201</b>	<b>0</b>	<b>322</b>	<b>523</b>	<b>523</b>	<b>1513</b>

Heavy Vehicles are vehicles having one rear axle with four or more wheels, or having two or more rear axles. These vehicles include most O.C. Transpo, school and inter-city buses. Further, they ARE included in the Turning Movement Count Summary.





## Appendix A-2

### Turning Movement Counts – Carp Road and Richardson Side Road





**CARP RD and RICHARDSON SIDE RD**  
(ULRS Listing RR- 5 & RICHRDSN)

Survey Date: Thursday 4 May 2006  
 Conditions: DRY  
 Start Time: 0700

**Total Observed U-Turns**  
 Northbound: 0 Southbound: 0  
 Eastbound: 0 Westbound: 0

**AADT Factor**  
 Thursday in May is  
 9

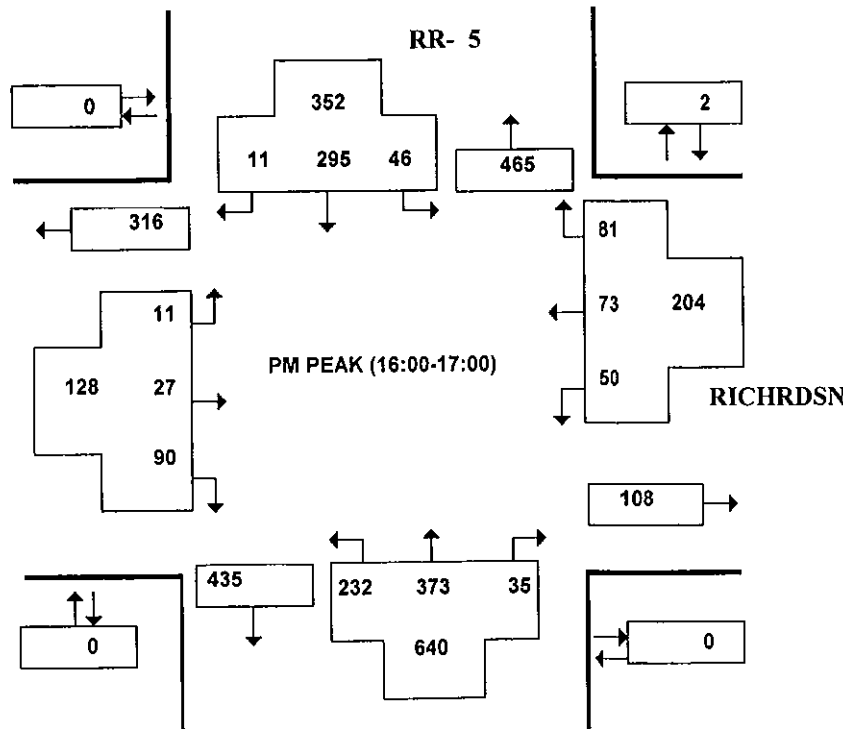
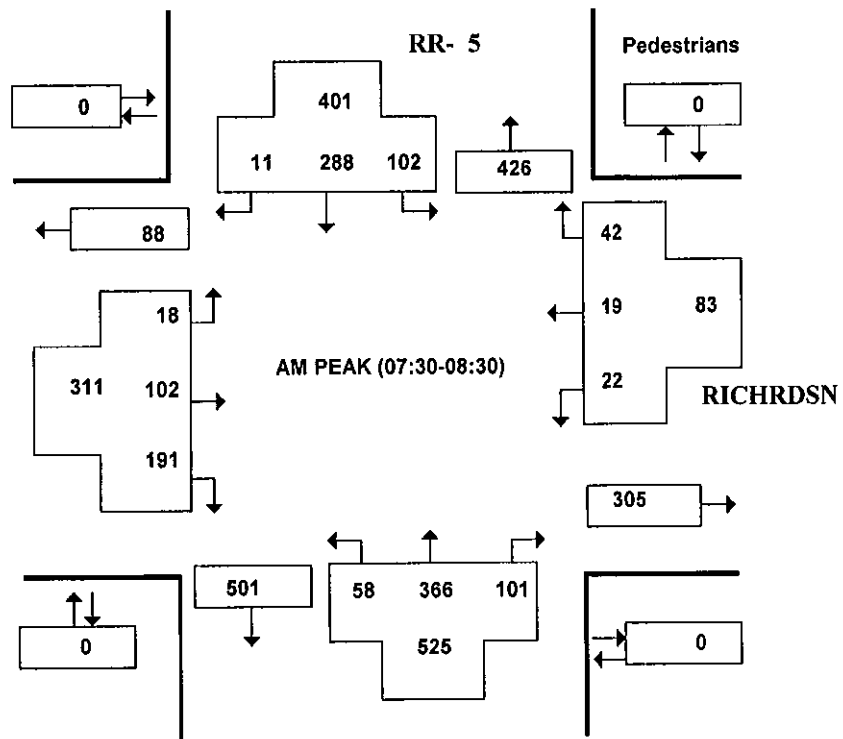



Vehicular Turning Movements - Summary

**CARP RD and RICHARDSON SIDE RD**

(ULRS Listing RR- 5 & RICHRDSN)

Survey Date: Thursday 4 May 2006  
 Conditions: DRY  
 Start Time: 0700

Total Observed U-Turns  
 Northbound: 0 Southbound: 0  
 Eastbound: 0 Westbound: 0

AADT Factor  
 Thursday in May is  
 9

Time Period	RR- 5									RICHRDSN									GRAND TOT
	Northbound			SUB TOT	Southbound			SUB TOT	STR TOT	Eastbound			SUB TOT	Westbound			SUB TOT		
	LT	ST	RT		LT	ST	RT			LT	ST	RT		LT	ST	RT			
07:00-08:00	52	356	81	489	78	259	7	344	833	19	104	204	327	10	12	27	49	376	1209
08:00-09:00	72	320	85	477	84	300	10	394	871	19	75	155	249	27	26	46	99	348	1219
09:00-10:00	80	321	33	434	45	246	8	299	733	8	42	109	159	11	18	23	52	211	944
11:30-12:30	57	251	35	343	49	244	10	303	646	9	21	71	101	15	25	44	84	185	831
12:30-13:30	81	255	25	361	43	228	9	280	641	8	11	55	74	25	24	55	104	178	819
15:00-16:00	131	316	26	473	34	299	10	343	816	11	13	37	61	44	39	67	150	211	1027
16:00-17:00	232	373	35	640	46	295	11	352	992	11	27	90	128	50	73	81	204	332	1324
17:00-18:00	220	397	41	658	45	267	11	323	981	9	20	65	94	63	48	67	178	272	1253
<b>8.0 HR TOTAL</b>	<b>925</b>	<b>2589</b>	<b>361</b>	<b>3875</b>	<b>424</b>	<b>2138</b>	<b>76</b>	<b>2638</b>	<b>6513</b>	<b>94</b>	<b>313</b>	<b>786</b>	<b>1193</b>	<b>245</b>	<b>265</b>	<b>410</b>	<b>920</b>	<b>2113</b>	<b>8626</b>

EQU. 12 HR TOTAL 1285 3598 501 5384 589 2971 105 3665 9049 130 4351092 1657 340 368 569 1277 2934 11983

Note: These values are calculated by multiplying the totals by the appropriate expansion factor.

AVG. 12 HR TOTAL 1156 3238 450 4844 530 2673 94 3297 8141 117 391 982 1490 306 331 512 1149 2639 10780

Note: These volumes are calculated by multiplying the Equivalent 12 hr. totals by the AADT factor.

AVG. 24 HR TOTAL 1514 4241 589 6344 694 3501 123 4318 10662 153 512 1286 1951 400 433 670 1503 3454 14116

Note: These volumes were calculated by multiplying the Average Daily 12 hr totals by 1.31.

AM TOTAL (0700-0900) 124 676 166 966 162 559 17 738 1704 38 179 359 576 37 38 73 148 724 2428

PM TOTAL (1530-1730) 423 761 68 1252 85 626 26 737 1989 20 44 144 208 125 123 152 400 608 2597



Vehicular Turning Movements (15 Min. Volumes)

**CARP RD and RICHARDSON SIDE RD**

(ULRS Listing RR- 5 & RICHRDSN)

Survey Date: Thursday 4 May 2006  
 Conditions: DRY  
 Start Time: 07:00

**Total Observed U-Turns**  
 Northbound: 0 Southbound: 0  
 Eastbound: 0 Westbound: 0

**AADT Factor**  
 Thursday in May is  
 9

Time Period	RR- 5									RICHRDSN									SUB TOT	STR TOT	GRAND TOT
	Northbound			SUB TOT	Southbound			SUB TOT	STR TOT	Eastbound			SUB TOT	Westbound							
	LT	ST	RT		LT	ST	RT			LT	ST	RT		LT	ST	RT					
07:00-07:15	18	80	6	104	18	52	1	71	175	3	15	59	77	1	2	5	8	85	260		
07:15-07:30	11	69	19	99	12	75	1	88	187	6	33	46	85	4	2	7	13	98	285		
07:30-07:45	8	101	25	134	23	61	0	84	218	5	19	59	83	2	2	8	12	95	313		
07:45-08:00	15	106	31	152	25	71	5	101	253	5	37	40	82	3	6	7	16	98	351		
08:00-08:15	18	95	28	141	26	76	3	105	246	5	25	56	86	9	6	13	28	114	360		
08:15-08:30	17	64	17	98	28	80	3	111	209	3	21	36	60	8	5	14	27	87	296		
08:30-08:45	13	75	21	109	17	77	1	95	204	8	17	29	54	7	6	8	21	75	279		
08:45-09:00	24	86	19	129	13	67	3	83	212	3	12	34	49	3	9	11	23	72	284		
09:00-09:15	19	76	7	102	7	60	5	72	174	3	8	40	51	2	10	5	17	68	242		
09:15-09:30	23	86	5	114	10	51	0	61	175	2	19	37	58	5	6	5	16	74	249		
09:30-09:45	14	75	11	100	14	70	2	86	186	3	12	19	34	0	1	8	9	43	229		
09:45-10:00	24	84	10	118	14	65	1	80	198	0	3	13	16	4	1	5	10	26	224		
11:30-11:45	17	48	12	77	9	49	2	60	137	2	6	17	25	1	9	10	20	45	182		
11:45-12:00	11	54	10	75	15	47	0	62	137	3	4	23	30	5	8	9	22	52	189		
12:00-12:15	15	71	4	90	9	72	7	88	178	1	5	16	22	5	6	11	22	44	222		
12:15-12:30	14	78	9	101	16	76	1	93	194	3	6	15	24	4	2	14	20	44	238		
12:30-12:45	19	65	4	88	6	46	2	54	142	0	2	14	16	2	4	15	21	37	179		
12:45-13:00	27	53	5	85	12	59	3	74	159	3	2	18	23	3	4	7	14	37	196		
13:00-13:15	15	82	8	105	13	57	1	71	176	3	3	10	16	8	5	15	28	44	220		
13:15-13:30	20	55	8	83	12	66	3	81	164	2	4	13	19	12	11	18	41	60	224		
15:00-15:15	27	61	4	92	7	64	1	72	164	3	1	9	13	8	5	11	24	37	201		
15:15-15:30	25	60	9	94	9	61	3	73	167	4	6	12	22	4	13	19	36	58	225		
15:30-15:45	31	87	8	126	5	102	2	109	235	1	4	6	11	16	11	18	45	56	291		
15:45-16:00	48	108	5	161	13	72	4	89	250	3	2	10	15	16	10	19	45	60	310		
16:00-16:15	63	70	10	143	15	93	3	111	254	7	11	23	41	7	25	24	56	97	351		
16:15-16:30	60	105	5	170	14	75	1	90	260	1	6	14	21	9	21	21	51	72	332		
16:30-16:45	46	100	11	157	7	78	1	86	243	0	4	24	28	22	13	19	54	82	325		
16:45-17:00	63	98	9	170	10	49	6	65	235	3	6	29	38	12	14	17	43	81	316		
17:00-17:15	61	86	9	156	10	80	4	94	250	0	3	14	17	19	13	18	50	67	317		
17:15-17:30	51	107	11	169	11	77	5	93	262	5	8	24	37	24	16	16	56	93	355		
17:30-17:45	58	122	7	187	9	72	0	81	268	3	6	9	18	9	12	20	41	59	327		
17:45-18:00	50	82	14	146	15	38	2	55	201	1	3	18	22	11	7	13	31	53	254		



**CARP RD and RICHARDSON SIDE RD**

(ULRS Listing RR- 5 & RICHRDSN)

Survey Date : Thursday 4 May 2006

Conditions : DRY

Start Time : 0700

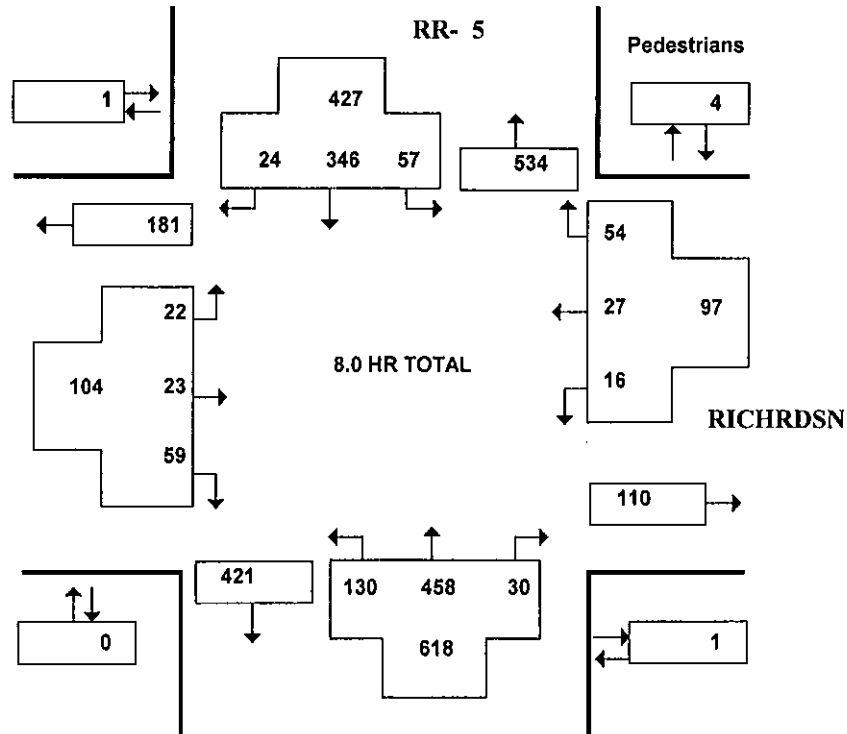

Time Period	RR- 5									RICHARDSN									
	Northbound			SUB TOT	Southbound			SUB TOT	STR TOT	Eastbound			SUB TOT	Westbound			SUB TOT	STR TOT	GRAND TOT
	LT	ST	RT		LT	ST	RT			LT	ST	RT		LT	ST	RT			
07:00-08:00	5	54	6	65	15	57	5	77	142	5	14	17	36	1	1	3	5	41	183
08:00-09:00	18	57	4	79	13	58	5	76	155	5	1	17	23	2	3	10	15	38	193
09:00-10:00	24	72	6	102	3	46	3	52	154	2	3	8	13	4	7	6	17	30	184
11:30-12:30	5	55	6	66	8	48	4	60	126	3	2	5	10	1	2	12	15	25	151
12:30-13:30	12	64	1	77	12	44	3	59	136	1	0	3	4	5	2	16	23	27	163
15:00-16:00	11	60	3	74	2	33	2	37	111	5	2	1	8	1	1	3	5	13	124
16:00-17:00	45	57	2	104	2	40	2	44	148	1	0	7	8	1	10	2	13	21	169
17:00-18:00	10	39	2	51	2	20	0	22	73	0	1	1	2	1	1	2	4	6	79
<b>8.0 HR TOTAL</b>	<b>130</b>	<b>458</b>	<b>30</b>	<b>618</b>	<b>57</b>	<b>346</b>	<b>24</b>	<b>427</b>	<b>1045</b>	<b>22</b>	<b>23</b>	<b>59</b>	<b>104</b>	<b>16</b>	<b>27</b>	<b>54</b>	<b>97</b>	<b>201</b>	<b>1246</b>

Heavy Vehicles are vehicles having one rear axle with four or more wheels, or having two or more rear axles. These vehicles include most O.C. Transpo, school and inter-city buses. Further, they ARE included in the Turning Movement Count Summary.

**CARP RD and RICHARDSON SIDE RD**  
(ULRS Listing RR- 5 & RICHRDSN)

**Survey Date:** Wednesday 24 July 2002  
**Conditions:** dry  
**Start Time:** 0700

**Total Observed U-Turns**  
 Northbound: 0 Southbound: 0  
 Eastbound: 0 Westbound: 0

**AADT Factor**  
 Wednesday in July is 9

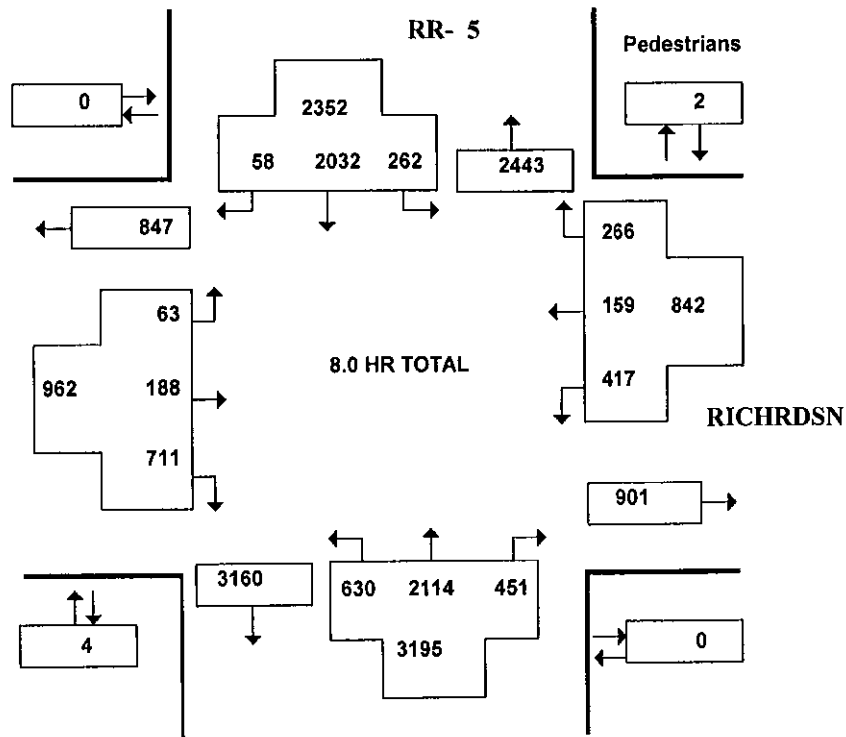



Vehicular Turning Movements - Summary

**CARP RD and RICHARDSON SIDE RD**

(ULRS Listing RR- 5 & RICHARDSN )

Survey Date: Wednesday 24 July 2002  
 Conditions: dry  
 Start Time: 0700

**Total Observed U-Turns**  
 Northbound: 0 Southbound: 0  
 Eastbound: 0 Westbound: 0

**AADT Factor**  
 Wednesday in July is  
 9

Time Period	RR- 5									RICHARDSN									GRAND TOT
	Northbound			SUB TOT	Southbound			SUB TOT	STR TOT	Eastbound			SUB TOT	Westbound			SUB TOT		
	LT	ST	RT		LT	ST	RT			LT	ST	RT		LT	ST	RT			
07:00-08:00	47	237	69	353	37	244	4	285	638	11	36	143	190	30	4	12	46	236	874
08:00-09:00	51	272	99	422	25	269	5	299	721	8	36	132	176	39	11	30	80	256	977
09:00-10:00	41	207	48	296	36	242	6	284	580	5	26	86	117	39	8	19	66	183	763
11:30-12:30	63	249	39	351	36	249	4	289	640	8	21	74	103	52	17	33	102	205	845
12:30-13:30	63	250	46	359	31	226	6	263	622	9	18	73	100	41	12	31	84	184	806
15:00-16:00	86	289	38	413	29	235	4	268	681	5	16	60	81	62	25	37	124	205	886
16:00-17:00	134	302	64	500	35	300	16	351	851	13	15	81	109	93	38	46	177	286	1137
17:00-18:00	145	308	48	501	33	267	13	313	814	4	20	62	86	61	44	58	163	249	1063
<b>8.0 HR TOTAL</b>	<b>630</b>	<b>2114</b>	<b>451</b>	<b>3195</b>	<b>262</b>	<b>2032</b>	<b>58</b>	<b>2352</b>	<b>5547</b>	<b>63</b>	<b>188</b>	<b>711</b>	<b>962</b>	<b>417</b>	<b>159</b>	<b>266</b>	<b>842</b>	<b>1804</b>	<b>7351</b>

AM TOTAL (0700-0900)	98	509	168	775	62	513	9	584	1359	19	72	275	366	69	15	42	126	492	1851
PM TOTAL (1530-1730)	260	634	112	1006	68	568	27	663	1669	18	36	154	208	172	77	80	329	537	2206





Vehicular Turning Movements (15 Min. Volumes)

**CARP RD and RICHARDSON SIDE RD**

(ULRS Listing RR- 5 & RICHRDSN)

Survey Date: Wednesday 24 July 2002  
 Conditions: dry  
 Start Time: 07:00

**Total Observed U-Turns**  
 Northbound: 0 Southbound: 0  
 Eastbound: 0 Westbound: 0

**AADT Factor**  
 Wednesday in July is  
 9

Time Period	RR- 5									RICHRDSN									SUB TOT	STR TOT	GRAND TOT
	Northbound			SUB TOT	Southbound			SUB TOT	STR TOT	Eastbound			SUB TOT	Westbound							
	LT	ST	RT		LT	ST	RT			LT	ST	RT		LT	ST	RT					
07:00-07:15	8	43	9	60	8	53	0	61	121	1	2	35	38	4	3	4	11	49	170		
07:15-07:30	9	59	17	85	12	67	1	80	165	4	6	31	41	3	1	2	6	47	212		
07:30-07:45	12	63	11	86	9	63	1	73	159	3	14	40	57	10	0	2	12	69	228		
07:45-08:00	18	72	32	122	8	61	2	71	193	3	14	37	54	13	0	4	17	71	264		
08:00-08:15	15	68	26	109	4	77	1	82	191	2	13	27	42	12	2	6	20	62	253		
08:15-08:30	6	69	26	101	9	69	1	79	180	3	7	38	48	10	0	9	19	67	247		
08:30-08:45	15	73	24	112	7	70	0	77	189	1	9	29	39	8	4	7	19	58	247		
08:45-09:00	15	62	23	100	5	53	3	61	161	2	7	38	47	9	5	8	22	69	230		
09:00-09:15	7	56	12	75	9	60	0	69	144	1	10	24	35	16	2	3	21	56	200		
09:15-09:30	12	53	16	81	9	52	3	64	145	1	3	24	28	9	0	5	14	42	187		
09:30-09:45	15	60	14	89	10	58	2	70	159	1	8	20	29	7	4	5	16	45	204		
09:45-10:00	7	38	6	51	8	72	1	81	132	2	5	18	25	7	2	6	15	40	172		
11:30-11:45	18	66	10	94	7	56	0	63	157	2	6	27	35	16	4	14	34	69	226		
11:45-12:00	12	61	11	84	5	67	1	73	157	3	7	10	20	12	4	5	21	41	198		
12:00-12:15	14	54	11	79	12	81	1	94	173	2	7	18	27	11	5	6	22	49	222		
12:15-12:30	19	68	7	94	12	45	2	59	153	1	1	19	21	13	4	8	25	46	199		
12:30-12:45	27	68	13	108	8	51	3	62	170	5	4	23	32	6	1	10	17	49	219		
12:45-13:00	17	63	9	89	6	53	1	60	149	2	4	22	28	9	4	9	22	50	199		
13:00-13:15	10	66	7	83	10	62	1	73	156	2	6	19	27	17	5	9	31	58	214		
13:15-13:30	9	53	17	79	7	60	1	68	147	0	4	9	13	9	2	3	14	27	174		
15:00-15:15	26	65	8	99	5	61	1	67	166	2	4	11	17	9	4	13	26	43	209		
15:15-15:30	16	60	9	85	12	64	1	77	162	1	1	17	19	15	6	10	31	50	212		
15:30-15:45	18	83	7	108	4	45	0	49	157	0	7	11	18	14	10	3	27	45	202		
15:45-16:00	26	81	14	121	8	65	2	75	196	2	4	21	27	24	5	11	40	67	263		
16:00-16:15	23	84	16	123	6	74	2	82	205	3	3	22	28	22	7	13	42	70	275		
16:15-16:30	31	86	17	134	7	78	5	90	224	3	7	19	29	20	8	15	43	72	296		
16:30-16:45	34	60	19	113	17	74	5	96	209	4	2	27	33	22	10	7	39	72	281		
16:45-17:00	46	72	12	130	5	74	4	83	213	3	3	13	19	29	13	11	53	72	285		
17:00-17:15	48	79	15	142	9	80	7	96	238	3	3	17	23	20	9	9	38	61	299		
17:15-17:30	34	89	12	135	12	78	2	92	227	0	7	24	31	21	15	11	47	78	305		
17:30-17:45	36	76	13	125	9	60	2	71	196	0	4	11	15	7	6	24	37	52	248		
17:45-18:00	27	64	8	99	3	49	2	54	153	1	6	10	17	13	14	14	41	58	211		



Heavy Vehicle Summary Sheet - Hourly Volumes

CARP RD and RICHARDSON SIDE RD

(ULRS Listing RR- 5 & RICHRDSN)

Survey Date : Wednesday 24 July 2002

Conditions : dry

Start Time : 0700

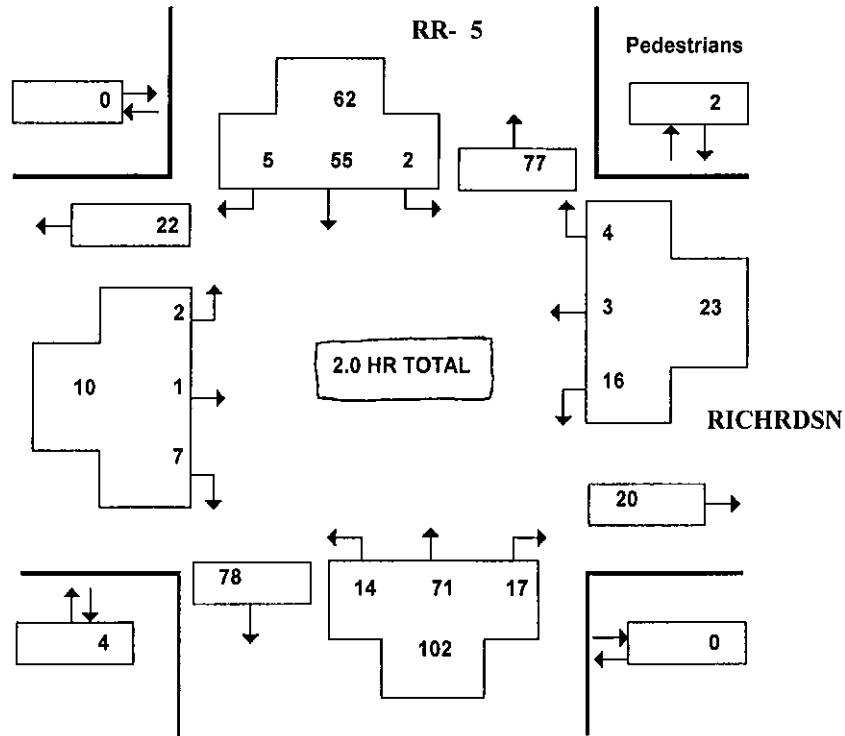

Time Period	RR- 5									RICHARDSN									
	Northbound			SUB TOT	Southbound			SUB TOT	STR TOT	Eastbound			SUB TOT	Westbound			SUB TOT	STR TOT	GRAND TOT
	LT	ST	RT		LT	ST	RT			LT	ST	RT		LT	ST	RT			
15:30-16:30	7	42	11	60	0	34	2	36	96	1	1	2	4	11	2	2	15	19	115
16:30-17:30	7	29	6	42	2	21	3	26	68	1	0	5	6	5	1	2	8	14	82
<b>2.0 HR TOTAL</b>	<b>14</b>	<b>71</b>	<b>17</b>	<b>102</b>	<b>2</b>	<b>55</b>	<b>5</b>	<b>62</b>	<b>164</b>	<b>2</b>	<b>1</b>	<b>7</b>	<b>10</b>	<b>16</b>	<b>3</b>	<b>4</b>	<b>23</b>	<b>33</b>	<b>197</b>

Heavy Vehicles are vehicles having one rear axle with four or more wheels, or having two or more rear axles. These vehicles include most O.C. Transpo, school and inter-city buses. Further, they ARE included in the Turning Movement Count Summary.

**CARP RD and RICHARDSON SIDE RD**  
(ULRS Listing RR- 5 & RICHRDSN)

Survey Date: Friday 30 July 1999  
 Conditions: Dry  
 Start Time: 0700

**Total Observed U-Turns**  
 Northbound: 0 Southbound: 0  
 Eastbound: 0 Westbound: 0

**AADT Factor**  
 Friday in July is  
 9

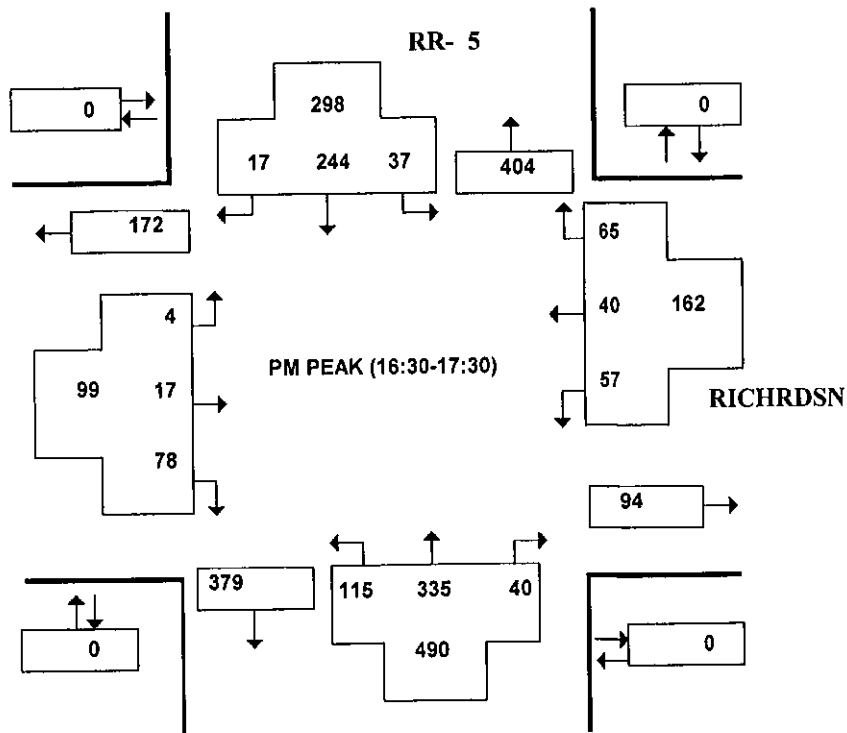
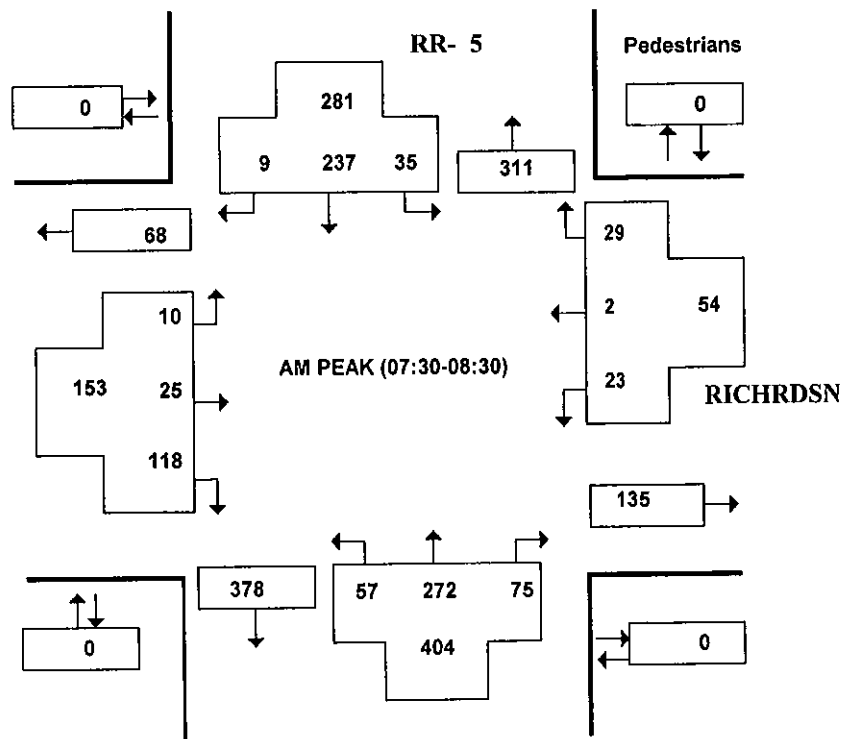

Vehicular Turning Movements - Summary

**CARP RD and RICHARDSON SIDE RD**

(ULRS Listing RR- 5 & RICHRDSN )

Survey Date: Friday 30 July 1999  
 Conditions: Dry  
 Start Time: 0700

Total Observed U-Turns  
 Northbound: 0 Southbound: 0  
 Eastbound: 0 Westbound: 0

AADT Factor  
 Friday in July is  
 9

Time Period	RR- 5									RICHRDSN									
	Northbound			SUB TOT	Southbound			SUB TOT	STR TOT	Eastbound			SUB TOT	Westbound			SUB TOT	STR TOT	GRAND TOT
	LT	ST	RT		LT	ST	RT			LT	ST	RT		LT	ST	RT			
07:00-08:00	53	237	68	358	23	228	9	260	618	7	27	115	149	17	5	19	41	190	808
08:00-09:00	39	261	66	366	36	223	6	265	631	17	22	106	145	29	5	29	63	208	839
09:00-10:00	36	198	40	274	24	201	4	229	503	5	21	77	103	30	13	10	53	156	659
11:30-12:30	54	224	40	318	32	217	13	262	580	8	14	57	79	29	19	25	73	152	732
12:30-13:30	83	253	51	387	27	246	4	277	664	6	11	76	93	46	20	40	106	199	863
15:00-16:00	76	270	47	393	28	216	9	253	646	7	18	61	86	57	21	35	113	199	845
16:00-17:00	115	311	52	478	43	241	15	299	777	7	12	82	101	69	45	46	160	261	1038
17:00-18:00	105	306	28	439	28	233	10	271	710	3	20	62	85	59	38	42	139	224	934
<b>8.0 HR TOTAL</b>	<b>561</b>	<b>2060</b>	<b>392</b>	<b>3013</b>	<b>241</b>	<b>1805</b>	<b>70</b>	<b>2116</b>	<b>5129</b>	<b>60</b>	<b>145</b>	<b>636</b>	<b>841</b>	<b>336</b>	<b>166</b>	<b>246</b>	<b>748</b>	<b>1589</b>	<b>6718</b>

EQU. 12 HR TOTAL 779 2863 544 4186 334 2508 97 2939 7125 83 201 884 1168 467 230 341 1038 2206 9331

Note: These values are calculated by multiplying the totals by the appropriate expansion factor.

AVG. 12 HR TOTAL 701 2576 489 3766 300 2257 87 2644 6410 74 180 795 1049 420 207 306 933 1982 8392

Note: These volumes are calculated by multiplying the Equivalent 12 hr. totals by the AADT factor.

AVG. 24 HR TOTAL 918 3374 640 4932 393 2956 113 3462 8394 96 235 1041 1372 550 271 400 1221 2593 10987

Note: These volumes were calculated by multiplying the Average Daily 12 hr totals by 1.31.

AM TOTAL (0700-0900) 92 498 134 724 59 451 15 525 1249 24 49 221 294 46 10 48 104 398 1647

PM TOTAL (1530-1730) 210 621 95 926 72 494 26 592 1518 17 37 154 208 135 73 102 310 518 2036



Vehicular Turning Movements (15 Min. Volumes)

**CARP RD and RICHARDSON SIDE RD**

(ULRS Listing RR- 5 & RICHRDSN)

Survey Date: Friday 30 July 1999  
 Conditions: Dry  
 Start Time: 07:00

Total Observed U-Turns  
 Northbound: 0 Southbound: 0  
 Eastbound: 0 Westbound: 0

AADT Factor  
 Friday in July is  
 9

Time Period	RR- 5									RICHRDSN									SUB TOT	STR TOT	GRAND TOT
	Northbound			SUB TOT	Southbound			SUB TOT	STR TOT	Eastbound			SUB TOT	Westbound							
	LT	ST	RT		LT	ST	RT			LT	ST	RT		LT	ST	RT					
07:00-07:15	13	57	14	84	2	46	1	49	133	3	4	28	35	2	2	5	9	44	177		
07:15-07:30	8	48	14	70	4	55	1	60	130	2	8	25	35	5	2	6	13	48	178		
07:30-07:45	24	52	21	97	6	54	3	63	160	0	8	30	38	3	0	3	6	44	204		
07:45-08:00	8	80	19	107	11	73	4	88	195	2	7	32	41	7	1	5	13	54	249		
08:00-08:15	11	76	22	109	10	58	1	69	178	6	6	30	42	4	0	8	12	54	232		
08:15-08:30	14	64	13	91	8	52	1	61	152	2	4	26	32	9	1	13	23	55	207		
08:30-08:45	5	60	24	89	11	48	1	60	149	3	4	27	34	11	1	6	18	52	201		
08:45-09:00	9	61	7	77	7	65	3	75	152	6	8	23	37	5	3	2	10	47	199		
09:00-09:15	9	59	10	78	4	58	1	63	141	1	3	32	36	9	1	2	12	48	189		
09:15-09:30	6	45	11	62	10	50	1	61	123	1	8	14	23	6	4	3	13	36	159		
09:30-09:45	10	49	12	71	7	51	0	58	129	0	7	10	17	8	2	3	13	30	159		
09:45-10:00	11	45	7	63	3	42	2	47	110	3	3	21	27	7	6	2	15	42	152		
11:30-11:45	14	55	7	76	6	45	3	54	130	2	2	15	19	9	6	3	18	37	167		
11:45-12:00	13	50	13	76	7	61	4	72	148	4	3	11	18	8	4	4	16	34	182		
12:00-12:15	13	56	10	79	12	51	2	65	144	0	4	15	19	10	8	10	28	47	191		
12:15-12:30	14	63	10	87	7	60	4	71	158	2	5	16	23	2	1	8	11	34	192		
12:30-12:45	14	64	16	94	7	62	1	70	164	1	0	23	24	15	2	11	28	52	216		
12:45-13:00	20	52	11	83	7	64	2	73	156	2	3	13	18	12	8	15	35	53	209		
13:00-13:15	24	65	12	101	7	62	0	69	170	2	4	24	30	6	3	4	13	43	213		
13:15-13:30	25	72	12	109	6	58	1	65	174	1	4	16	21	13	7	10	30	51	225		
15:00-15:15	15	57	7	79	10	65	2	77	156	0	5	19	24	16	6	5	27	51	207		
15:15-15:30	17	71	14	102	4	40	4	48	150	0	0	5	5	7	8	8	23	28	178		
15:30-15:45	23	75	12	110	7	61	1	69	179	4	6	17	27	17	2	13	32	59	238		
15:45-16:00	21	67	14	102	7	50	2	59	161	3	7	20	30	17	5	9	31	61	222		
16:00-16:15	33	78	11	122	13	79	3	95	217	3	2	26	31	16	9	9	34	65	282		
16:15-16:30	18	66	18	102	8	60	3	71	173	3	5	13	21	28	17	6	51	72	245		
16:30-16:45	38	87	11	136	10	51	3	64	200	1	3	21	25	8	14	13	35	60	260		
16:45-17:00	26	80	12	118	12	51	6	69	187	0	2	22	24	17	5	18	40	64	251		
17:00-17:15	29	89	10	128	9	77	6	92	220	1	7	9	17	18	12	17	47	64	284		
17:15-17:30	22	79	7	108	6	65	2	73	181	2	5	26	33	14	9	17	40	73	254		
17:30-17:45	26	69	6	101	5	47	0	52	153	0	4	9	13	14	10	6	30	43	196		
17:45-18:00	28	69	5	102	8	44	2	54	156	0	4	18	22	13	7	2	22	44	200		



Heavy Vehicle Summary Sheet - Hourly Volumes

CARP RD and RICHARDSON SIDE RD

(ULRS Listing RR- 5 & RICHRDSN)

Survey Date :Friday 30 July 1999

Conditions : Dry

Start Time : 0700

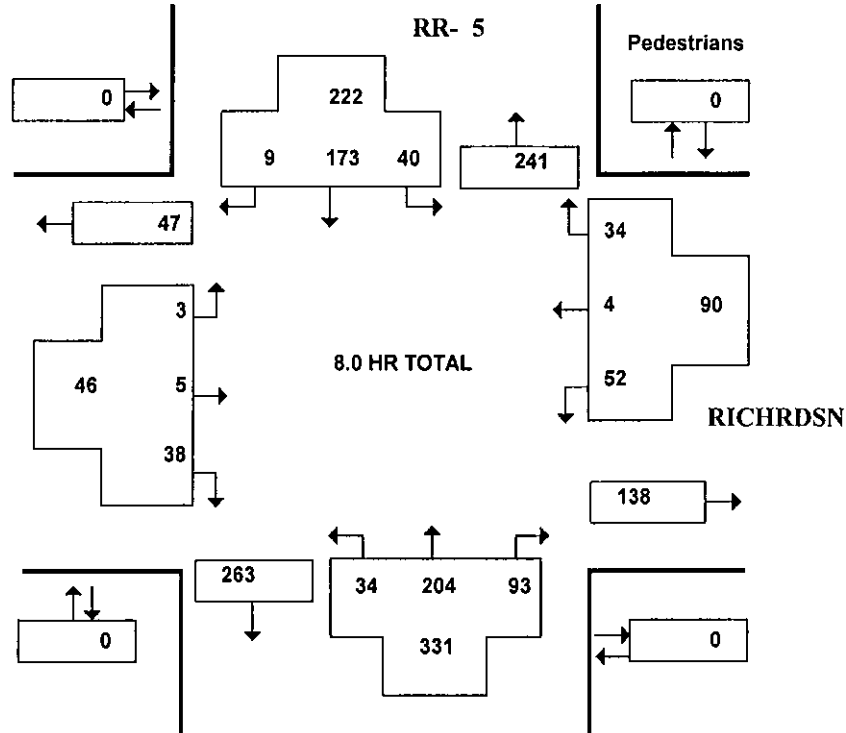

Time Period	RR- 5									RICHARDSN									
	Northbound			SUB TOT	Southbound			SUB TOT	STR TOT	Eastbound			SUB TOT	Westbound			SUB TOT	STR TOT	GRAND TOT
	LT	ST	RT		LT	ST	RT			LT	ST	RT		LT	ST	RT			
07:00-08:00	6	24	7	37	4	27	0	31	68	0	1	5	6	6	0	2	8	14	82
08:00-09:00	7	28	12	47	3	27	2	32	79	0	0	6	6	6	0	3	9	15	94
09:00-10:00	5	22	9	36	5	18	0	23	59	0	1	5	6	7	0	2	9	15	74
11:30-12:30	4	26	11	41	5	21	3	29	70	0	0	3	3	7	1	4	12	15	85
12:30-13:30	3	34	13	50	6	31	0	37	87	1	0	8	9	9	0	4	13	22	109
15:00-16:00	1	24	20	45	7	18	1	26	71	1	2	6	9	10	0	6	16	25	96
16:00-17:00	6	26	18	50	8	18	2	28	78	0	0	1	1	5	1	8	14	15	93
17:00-18:00	2	20	3	25	2	13	1	16	41	1	1	4	6	2	2	5	9	15	56
<b>8.0 HR TOTAL</b>	<b>34</b>	<b>204</b>	<b>93</b>	<b>331</b>	<b>40</b>	<b>173</b>	<b>9</b>	<b>222</b>	<b>553</b>	<b>3</b>	<b>5</b>	<b>38</b>	<b>46</b>	<b>52</b>	<b>4</b>	<b>34</b>	<b>90</b>	<b>136</b>	<b>689</b>

Heavy Vehicles are vehicles having one rear axle with four or more wheels, or having two or more rear axles. These vehicles include most O.C. Transpo, school and inter-city buses. Further, they ARE included in the Turning Movement Count Summary.

**CARP RD and RICHARDSON SIDE RD**  
(ULRS Listing RR- 5 & RICHRDSN)

**Survey Date:** Thursday 23 July 1998  
**Conditions:** Dry  
**Start Time:** 0700

**Total Observed U-Turns**  
Northbound: 0 Southbound: 0  
Eastbound: 0 Westbound: 0

**AADT Factor**  
Thursday in July is 9

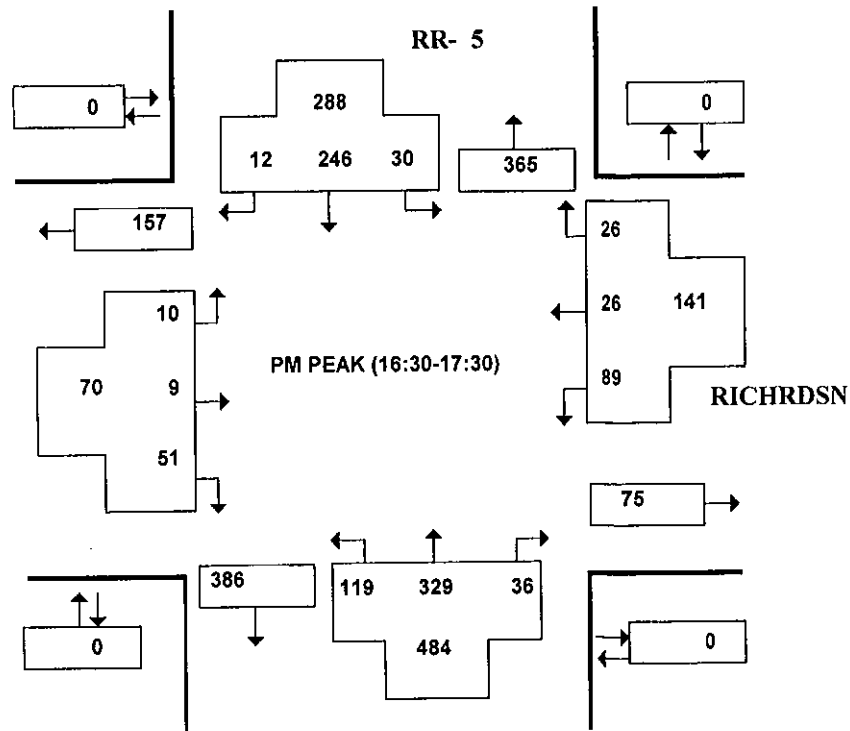
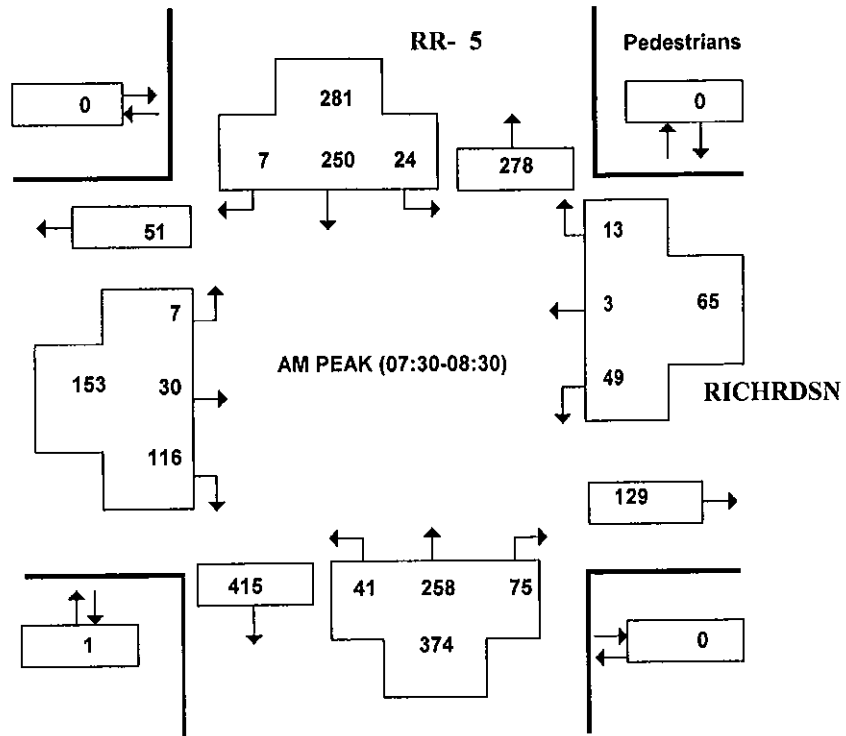



Vehicular Turning Movements - Summary

**CARP RD and RICHARDSON SIDE RD**

(ULRS Listing RR- 5 & RICHRDSN)

Survey Date: Thursday 23 July 1998  
 Conditions: Dry  
 Start Time: 0700

Total Observed U-Turns  
 Northbound: 0 Southbound: 0  
 Eastbound: 0 Westbound: 0

AADT Factor  
 Thursday in July is  
 9

Time Period	RR- 5										RICHRDSN									
	Northbound			SUB TOT	Southbound			SUB TOT	STR TOT	Eastbound			SUB TOT	Westbound			SUB TOT	STR TOT	GRAND TOT	
	LT	ST	RT		LT	ST	RT			LT	ST	RT		LT	ST	RT				
07:00-08:00	34	226	56	316	24	244	5	273	589	6	25	130	161	27	5	7	39	200	789	
08:00-09:00	38	243	58	339	20	233	7	260	599	8	27	103	138	44	3	27	74	212	811	
09:00-10:00	43	158	55	256	13	183	4	200	456	7	19	78	104	30	8	18	56	160	616	
11:30-12:30	47	195	51	293	21	201	15	237	530	10	11	59	80	29	10	17	56	136	666	
12:30-13:30	43	225	33	301	26	166	3	195	496	3	4	62	69	32	8	24	64	133	629	
15:00-16:00	63	261	52	376	24	242	8	274	650	7	9	66	82	36	10	19	65	147	797	
16:00-17:00	108	321	45	474	31	217	9	257	731	10	7	44	61	93	24	37	154	215	946	
17:00-18:00	111	315	34	460	25	255	12	292	752	7	10	58	75	63	23	24	110	185	937	
18:00-19:00	83	202	31	316	15	157	8	180	496	11	12	73	96	33	19	23	75	171	667	
19:00-20:00	66	131	20	217	10	95	7	112	329	2	14	38	54	40	15	13	68	122	451	
20:00-21:00	71	120	27	218	14	174	5	193	411	1	10	38	49	39	10	21	70	119	530	
<b>11.0 HR TOTAL</b>	<b>707</b>	<b>2397</b>	<b>462</b>	<b>3566</b>	<b>223</b>	<b>2167</b>	<b>83</b>	<b>2473</b>	<b>6039</b>	<b>72</b>	<b>148</b>	<b>749</b>	<b>969</b>	<b>466</b>	<b>135</b>	<b>230</b>	<b>831</b>	<b>1800</b>	<b>7839</b>	

EQU. 12 HR TOTAL 676 2702 533 3911 255 2419 87 2761 6672 80 155 834 1069 492 126 240 858 1927 8599

Note: These values are calculated by multiplying the totals by the appropriate expansion factor.

AVG. 12 HR TOTAL 608 2431 479 3518 229 2177 78 2484 6002 72 139 750 961 442 113 216 771 1732 7734

Note: These volumes are calculated by multiplying the Equivalent 12 hr. totals by the AADT factor.

AVG. 24 HR TOTAL 796 3184 627 4607 299 2851 102 3252 7859 94 182 982 1258 579 148 282 1009 2267 10126

Note: These volumes were calculated by multiplying the Average Daily 12 hr totals by 1.31.

AM TOTAL (0700-0900) 72 469 114 655 44 477 12 533 1188 14 52 233 299 71 8 34 113 412 1600

PM TOTAL (1530-1730) 194 623 85 902 56 485 22 563 1465 15 16 115 146 152 41 56 249 395 1860





Vehicular Turning Movements (15 Min. Volumes)

CARP RD and RICHARDSON SIDE RD

(ULRS Listing RR- 5 & RICHARDSN)

Survey Date: Thursday 23 July 1998
Conditions: Dry
Start Time: 07:00

Total Observed U-Turns
Northbound: 0 Southbound: 0
Eastbound: 0 Westbound: 0

AADT Factor
Thursday in July is 9

Table with columns for Time Period, RR-5 (Northbound, Southbound), RICHARDSN (Eastbound, Westbound), and Grand Totals (SUB TOT, STR TOT, GRAND TOT). Rows represent 15-minute intervals from 07:00-07:15 to 19:00-19:15.



Vehicular Turning Movements (15 Min. Volumes)

**CARP RD and RICHARDSON SIDE RD**

(ULRS Listing RR- 5 & RICHRDSN)

Survey Date: Thursday 23 July 1998  
 Conditions: Dry  
 Start Time: 07:00

Total Observed U-Turns  
 Northbound: 0 Southbound: 0  
 Eastbound: 0 Westbound: 0

AADT Factor  
 Thursday in July is  
 9

Time Period	RR- 5									RICHRDSN									
	Northbound			SUB TOT	Southbound			SUB TOT	STR TOT	Eastbound			SUB TOT	Westbound			SUB TOT	STR TOT	GRAND TOT
	LT	ST	RT		LT	ST	RT			LT	ST	RT		LT	ST	RT			
19:15-19:30	16	29	2	47	3	19	1	23	70	0	5	6	11	4	2	4	10	21	91
19:30-19:45	18	38	12	68	1	35	3	39	107	2	4	12	18	8	2	3	13	31	138
19:45-20:00	12	27	3	42	1	11	2	14	56	0	2	10	12	12	5	0	17	29	85
20:00-20:15	17	32	8	57	3	27	1	31	88	1	2	8	11	13	3	6	22	33	121
20:15-20:30	19	38	6	63	0	41	2	43	106	0	7	9	16	6	1	3	10	26	132
20:30-20:45	15	26	5	46	5	32	0	37	83	0	0	11	11	16	2	4	22	33	116
20:45-21:00	20	24	8	52	6	74	2	82	134	0	1	10	11	4	4	8	16	27	161



Heavy Vehicle Summary Sheet - Hourly Volumes

CARP RD and RICHARDSON SIDE RD

(ULRS Listing RR- 5 & RICHRDSN)

Survey Date :Thursday 23 July 1998

Conditions : Dry

Start Time : 0700

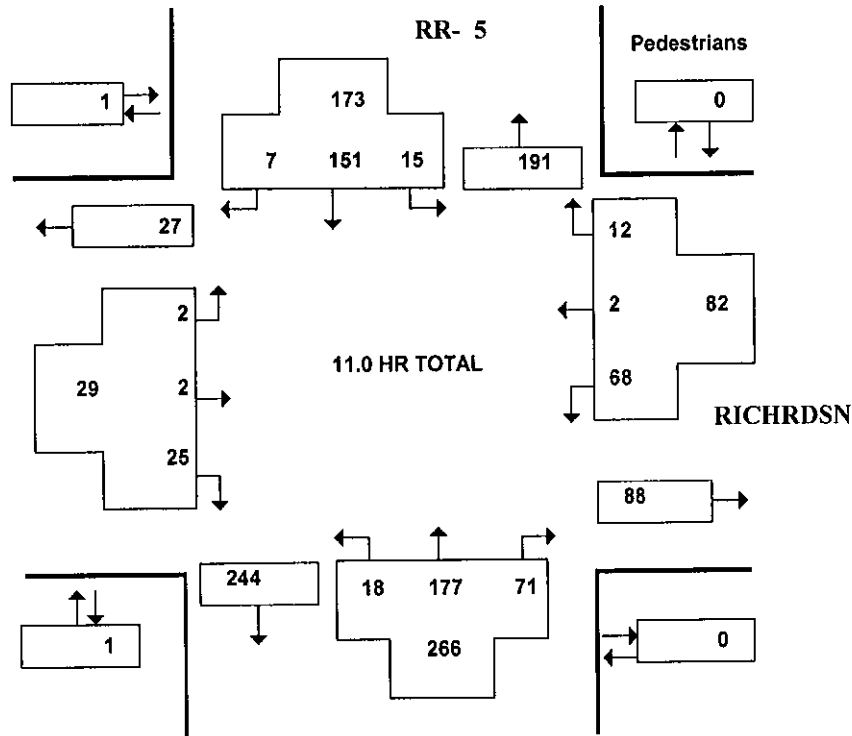

Time Period	RR- 5										RICHARDSON								
	Northbound				Southbound						Eastbound			Westbound					
	LT	ST	RT	SUB TOT	LT	ST	RT	SUB TOT	STR TOT	LT	ST	RT	SUB TOT	LT	ST	RT	SUB TOT	STR TOT	GRAND TOT
07:00-08:00	2	20	6	28	2	30	0	32	60	1	1	3	5	5	0	2	7	12	72
08:00-09:00	4	16	9	29	3	24	1	28	57	0	0	3	3	15	0	0	15	18	75
09:00-10:00	1	20	12	33	1	18	0	19	52	0	0	2	2	9	0	1	10	12	64
11:30-12:30	4	19	13	36	0	21	1	22	58	1	0	4	5	8	1	1	10	15	73
12:30-13:30	1	21	10	32	1	15	0	16	48	0	1	3	4	9	0	4	13	17	65
15:00-16:00	1	28	13	42	1	23	1	25	67	0	0	7	7	9	0	2	11	18	85
16:00-17:00	1	23	8	32	3	10	1	14	46	0	0	1	1	9	0	1	10	11	57
17:00-18:00	1	17	0	18	1	6	1	8	26	0	0	0	0	0	0	0	0	0	26
18:00-19:00	2	12	0	14	2	3	1	6	20	0	0	2	2	2	1	0	3	5	25
19:00-20:00	1	0	0	1	1	1	1	3	4	0	0	0	0	2	0	1	3	3	7
20:00-21:00	0	1	0	1	0	0	0	0	1	0	0	0	0	0	0	0	0	0	1
<b>11.0 HR TOTAL</b>	<b>18</b>	<b>177</b>	<b>71</b>	<b>266</b>	<b>15</b>	<b>151</b>	<b>7</b>	<b>173</b>	<b>439</b>	<b>2</b>	<b>2</b>	<b>25</b>	<b>29</b>	<b>68</b>	<b>2</b>	<b>12</b>	<b>82</b>	<b>111</b>	<b>550</b>

Heavy Vehicles are vehicles having one rear axle with four or more wheels, or having two or more rear axles. These vehicles include most O.C. Transpo, school and inter-city buses. Further, they ARE included in the Turning Movement Count Summary.

**Bicycle Volume Summary Sheet - Hourly Volumes**

**CARP RD and RICHARDSON SIDE RD**

(ULRS Listing RR- 5 & RICHRDSN)

Survey Date: Thursday 23 July 1998

Conditions: Dry

Start Time: 0700

Time Period	NORTHBOUND APPROACH ON RR- 5	SOUTHBOUND APPROACH ON RR- 5	STREET TOTAL	EASTBOUND APPROACH ON RICHRDSN	WESTBOUND APPROACH ON RICHRDSN	STREET TOTAL	GRAND TOTAL
07:00-08:00	0	0	0	1	0	1	1
08:00-09:00	0	0	0	1	4	5	5
09:00-10:00	0	0	0	2	2	4	4
11:30-12:30	1	1	2	0	0	0	2
12:30-13:30	2	1	3	0	0	0	3
15:00-16:00	0	0	0	9	0	9	9
16:00-17:00	0	0	0	0	1	1	1
17:00-18:00	0	0	0	0	0	0	0
18:00-19:00	0	1	1	0	1	1	2
19:00-20:00	0	1	1	0	0	0	1
20:00-21:00	0	0	0	0	0	0	0
<b>11.0 HR TOTAL</b>	<b>3</b>	<b>4</b>	<b>7</b>	<b>13</b>	<b>8</b>	<b>21</b>	<b>28</b>

Note: These volumes consists of bicycles only (no mopeds or motorcycles) and ARE NOT included in the Turning Movement Count Summary.



## Appendix A-3

### 2010 Ramp Counts





# MINISTRY OF TRANSPORTATION INTERCHANGE FILE

<b>HWY. 417 IC 144</b>	KEYPOINT NUMBER 49570/000
<b>AT CARP RD. REG. RD. 5</b>	M.T.O. DISTRICT OTTAWA
	O.P.P. DISTRICT 11 LONG SAULT

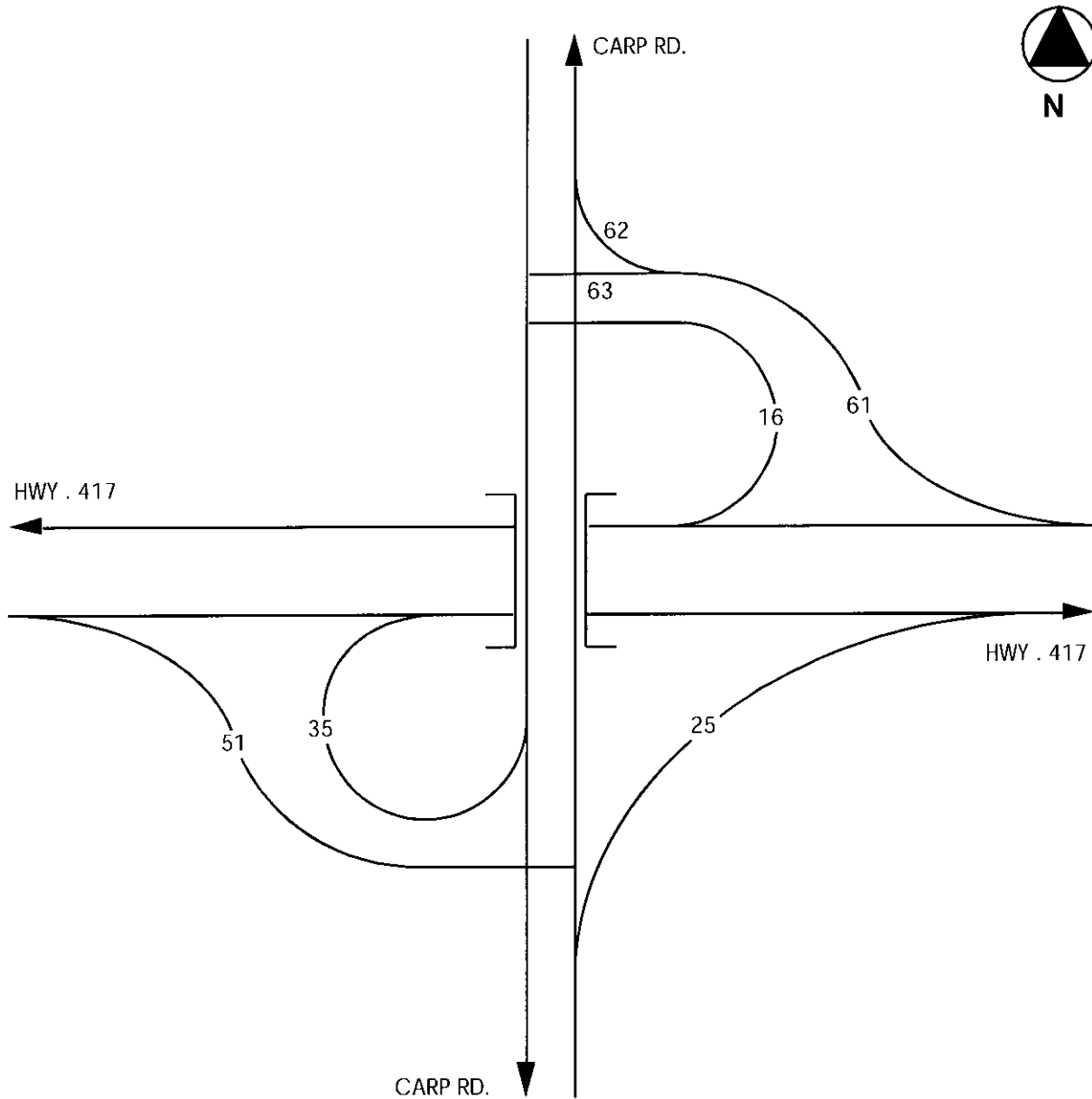

# Weekly Volume Summary

Tue, Apr 19, 2011

**Location:** Hwy 417 WB off ramp to Carp NB/SB *Ramp 61*  
**LHRS/Offset:** 49570 / 0.0 **Region:** Eastern  
**Pattern Type:** n/a **PCS#:** n/a **Hwy. TVIS#:** 49570061  
**Count Direction:** N/A **Report Dates:** Aug 29, 2010 to Sep 4, 2010

Hour Interval	Sun 10/08/29	Mon 30	Tue 31	Wed 1	Thu 2	Fri 3	Sat 4	Sun 5
0:00- 1:00		45	53	80	76	79	131	80
1:00- 2:00		18	33	42	34	43	65	59
2:00- 3:00		6	18	16	31	35	52	27
3:00- 4:00		26	23	13	26	19	41	22
4:00- 5:00		20	34	42	22	35	20	14
5:00- 6:00		158	139	182	175	127	31	31
6:00- 7:00		495	498	509	488	458	105	64
7:00- 8:00		602	680	677	736	665	220	115
8:00- 9:00		671	664	671	722	691	348	133
9:00-10:00		588	624	642	604	613	524	183
10:00-11:00		654	571	650	665	645	619	305
11:00-12:00		712	743	745	793	797	603	343
AM Total	0	3,995	4,080	4,269	4,372	4,207	2,759	1,376
12:00-13:00	396	823	762	881	808	921	625	
13:00-14:00	401	792	823	836	875	1,014	614	
14:00-15:00	407	1,020	876	882	907	993	654	
15:00-16:00	396	1,082	1,041	1,095	1,077	982	613	
16:00-17:00	398	1,255	1,107	1,173	1,222	1,026	589	
17:00-18:00	317	1,220	1,248	1,192	1,132	864	520	
18:00-19:00	303	916	836	870	923	675	405	
19:00-20:00	277	537	549	590	617	525	287	
20:00-21:00	227	429	538	539	532	420	258	
21:00-22:00	157	306	403	425	431	357	275	
22:00-23:00	85	181	252	210	261	230	227	
23:00-24:00	76	123	122	131	151	171	171	
PM Total	3,440	8,684	8,557	8,824	8,936	8,178	5,238	0
24 Hr. Total	3,440	12,679	12,637	13,093	13,308	12,385	7,997	1,376
Noon - Noon	7,435	12,764	12,826	13,196	13,143	10,937	6,614	
	ADT 10,988	AWD 12,982	AADT	AAWD	SADT	SAWDT	WADT	DHV





Engineering



# Weekly Volume Summary

Tue, Apr 19, 2011

**Location:** Hwy 417 WB on ramp from Carp NB/SB

*Ramp 16*

**LHRS/Offset:** 49570 / 0.0

**Region:** Eastern

**Pattern Type:** n/a

**PCS#:** n/a

**Hwy. TVIS#:** 49570016

**Count Direction:** N/A

**Report Dates:** Aug 29, 2010 to Sep 4, 2010

Hour Interval	Sun 10/08/29	Mon 30	Tue 31	Wed 1	Thu 2	Fri 3	Sat 4	Sun 5
0:00- 1:00		3	7	3	7	5	14	5
1:00- 2:00		2	0	2	4	7	7	4
2:00- 3:00		0	3	1	0	1	6	2
3:00- 4:00		1	1	0	6	1	2	2
4:00- 5:00		8	2	2	6	6	3	3
5:00- 6:00		23	14	16	17	5	2	2
6:00- 7:00		63	60	77	68	54	25	19
7:00- 8:00		87	126	68	64	103	45	20
8:00- 9:00		79	116	91	129	105	84	33
9:00-10:00		140	111	99	91	114	105	44
10:00-11:00		97	101	102	122	125	127	71
11:00-12:00		107	137	104	108	167	164	80
<b>AM Total</b>	<b>0</b>	<b>610</b>	<b>678</b>	<b>565</b>	<b>622</b>	<b>693</b>	<b>584</b>	<b>285</b>
12:00-13:00	56	112	115	127	110	154	133	
13:00-14:00	68	136	102	120	130	180	107	
14:00-15:00	58	130	137	126	121	176	105	
15:00-16:00	47	167	156	165	157	213	108	
16:00-17:00	63	214	205	214	242	220	81	
17:00-18:00	40	165	173	171	213	216	61	
18:00-19:00	36	108	100	106	144	136	46	
19:00-20:00	36	48	62	68	57	87	38	
20:00-21:00	38	34	48	61	52	56	31	
21:00-22:00	16	21	36	43	50	42	23	
22:00-23:00	9	18	21	17	24	19	18	
23:00-24:00	8	11	19	15	15	17	14	
<b>PM Total</b>	<b>475</b>	<b>1,164</b>	<b>1,174</b>	<b>1,233</b>	<b>1,315</b>	<b>1,516</b>	<b>765</b>	<b>0</b>
<b>24 Hr. Total</b>	<b>475</b>	<b>1,774</b>	<b>1,852</b>	<b>1,798</b>	<b>1,937</b>	<b>2,209</b>	<b>1,349</b>	<b>285</b>
<b>Noon - Noon</b>	<b>1,085</b>	<b>1,842</b>	<b>1,739</b>	<b>1,855</b>	<b>2,008</b>	<b>2,100</b>	<b>1,050</b>	
	<b>ADT</b>	<b>AWD</b>	<b>AADT</b>	<b>AAWD</b>	<b>SADT</b>	<b>SAWDT</b>	<b>WADT</b>	<b>DHV</b>
	1,668	1,861						

# Weekly Volume Summary

Tue, Apr 19, 2011

**Location:** Hwy 417 EB on ramp from Carp NB *Ramp 25*  
**LHRS/Offset:** 49570 / 0.0 **Region:** Eastern  
**Pattern Type:** n/a **PCS#:** n/a **Hwy. TVIS#:** 49570025  
**Count Direction:** N/A **Report Dates:** Aug 29, 2010 to Sep 4, 2010

Hour Interval	Sun 10/08/29	Mon 30	Tue 31	Wed 1	Thu 2	Fri 3	Sat 4	Sun 5
0:00- 1:00		18	11	22	20	25	47	33
1:00- 2:00		6	12	13	14	12	27	22
2:00- 3:00		7	7	6	13	13	25	16
3:00- 4:00		6	14	10	17	10	19	5
4:00- 5:00		22	19	20	16	25	12	13
5:00- 6:00		132	136	126	135	109	38	36
6:00- 7:00		600	651	560	588	494	107	85
7:00- 8:00		834	908	868	819	763	181	58
8:00- 9:00		672	814	839	828	761	266	92
9:00-10:00		649	597	581	593	625	364	171
10:00-11:00		521	458	511	523	533	463	222
11:00-12:00		458	478	556	505	555	467	277
<b>AM Total</b>	<b>0</b>	<b>3,925</b>	<b>4,105</b>	<b>4,112</b>	<b>4,071</b>	<b>3,925</b>	<b>2,016</b>	<b>1,030</b>
12:00-13:00	268	521	515	537	495	561	438	
13:00-14:00	287	439	454	482	530	537	434	
14:00-15:00	256	415	447	472	468	513	427	
15:00-16:00	268	427	474	442	465	421	380	
16:00-17:00	219	504	488	500	495	473	359	
17:00-18:00	215	540	557	560	552	495	269	
18:00-19:00	175	467	455	445	447	418	261	
19:00-20:00	171	270	302	332	351	294	199	
20:00-21:00	116	184	195	232	211	197	150	
21:00-22:00	82	147	135	158	144	149	131	
22:00-23:00	60	77	98	99	69	112	93	
23:00-24:00	30	33	45	42	55	69	66	
<b>PM Total</b>	<b>2,147</b>	<b>4,024</b>	<b>4,165</b>	<b>4,301</b>	<b>4,282</b>	<b>4,239</b>	<b>3,207</b>	<b>0</b>
<b>24 Hr. Total</b>	<b>2,147</b>	<b>7,949</b>	<b>8,270</b>	<b>8,413</b>	<b>8,353</b>	<b>8,164</b>	<b>5,223</b>	<b>1,030</b>
<b>Noon - Noon</b>	<b>6,072</b>	<b>8,129</b>	<b>8,277</b>	<b>8,372</b>	<b>8,207</b>	<b>6,255</b>	<b>4,237</b>	
	<b>ADT</b>	<b>AWD</b>	<b>AADT</b>	<b>AAWD</b>	<b>SADT</b>	<b>SAWDT</b>	<b>WADT</b>	<b>DHV</b>
	7,078	8,246						

# Weekly Volume Summary

Tue, Apr 19, 2011

**Location:** Hwy 417 EB on ramp from Carp SB *Ramp 35*  
**LHRS/Offset:** 49570 / 0.0 **Region:** Eastern  
**Pattern Type:** n/a **PCS#:** n/a **Hwy. TVIS#:** 49570035  
**Count Direction:** N/A **Report Dates:** Aug 29, 2010 to Sep 4, 2010

Hour Interval	Sun 10/08/29	Mon 30	Tue 31	Wed 1	Thu 2	Fri 3	Sat 4	Sun 5
0:00- 1:00		5	8	18	9	18	14	10
1:00- 2:00		3	2	13	4	8	9	9
2:00- 3:00		3	3	5	5	8	5	3
3:00- 4:00		1	4	3	9	3	2	3
4:00- 5:00		12	10	12	9	8	4	2
5:00- 6:00		74	69	61	66	56	17	13
6:00- 7:00		239	268	270	269	223	26	23
7:00- 8:00		404	368	373	386	336	49	33
8:00- 9:00		345	312	367	349	322	112	44
9:00-10:00		240	259	269	262	255	188	54
10:00-11:00		280	253	277	249	279	266	102
11:00-12:00		260	242	248	283	272	275	125
<b>AM Total</b>	<b>0</b>	<b>1,866</b>	<b>1,798</b>	<b>1,916</b>	<b>1,900</b>	<b>1,788</b>	<b>967</b>	<b>421</b>
12:00-13:00	169	280	237	280	299	256	277	
13:00-14:00	160	316	203	251	248	273	266	
14:00-15:00	143	348	254	241	258	282	221	
15:00-16:00	120	334	257	294	298	290	186	
16:00-17:00	105	338	289	312	319	268	159	
17:00-18:00	90	266	261	251	266	210	104	
18:00-19:00	108	192	198	182	187	143	101	
19:00-20:00	79	97	150	113	129	104	78	
20:00-21:00	48	55	101	88	105	71	83	
21:00-22:00	38	51	73	76	73	49	61	
22:00-23:00	14	20	59	68	56	56	43	
23:00-24:00	11	6	17	40	27	21	39	
<b>PM Total</b>	<b>1,085</b>	<b>2,303</b>	<b>2,099</b>	<b>2,196</b>	<b>2,265</b>	<b>2,023</b>	<b>1,618</b>	<b>0</b>
<b>24 Hr. Total</b>	<b>1,085</b>	<b>4,169</b>	<b>3,897</b>	<b>4,112</b>	<b>4,165</b>	<b>3,811</b>	<b>2,585</b>	<b>421</b>
<b>Noon - Noon</b>	<b>2,951</b>	<b>4,101</b>	<b>4,015</b>	<b>4,096</b>	<b>4,053</b>	<b>2,990</b>	<b>2,039</b>	
	<b>ADT</b>	<b>AWD</b>	<b>AADT</b>	<b>AAWD</b>	<b>SADT</b>	<b>SAWDT</b>	<b>WADT</b>	<b>DHV</b>
	3,464	4,066						



Engineering



# Weekly Volume Summary

Tue, Apr 19, 2011

**Location:** Hwy 417 EB off ramp to Carp NB/SB

*Ramp 51*

**LHRS/Offset:** 49570 / 0.0

**Region:** Eastern

**Pattern Type:** n/a

**PCS#:** n/a

**Hwy. TVIS#:** 49570051

**Count Direction:** N/A

**Report Dates:** Aug 29, 2010 to Sep 4, 2010

Hour Interval	Sun 10/08/29	Mon 30	Tue 31	Wed 1	Thu 2	Fri 3	Sat 4	Sun 5
0:00- 1:00		1	9	7	7	6	1	10
1:00- 2:00		6	0	3	10	4	1	10
2:00- 3:00		5	2	5	8	8	0	1
3:00- 4:00		11	10	6	11	5	6	3
4:00- 5:00		17	23	14	16	13	7	7
5:00- 6:00		58	55	58	56	59	1	4
6:00- 7:00		183	192	214	191	214	17	16
7:00- 8:00		246	227	191	202	178	43	16
8:00- 9:00		167	175	155	159	141	61	20
9:00-10:00		126	119	115	90	133	79	30
10:00-11:00		129	115	119	91	111	77	56
11:00-12:00		119	94	102	87	113	79	109
<b>AM Total</b>	<b>0</b>	<b>1,068</b>	<b>1,021</b>	<b>989</b>	<b>928</b>	<b>985</b>	<b>372</b>	<b>282</b>
12:00-13:00	109	98	119	102	112	117	95	
13:00-14:00	151	109	90	109	126	111	80	
14:00-15:00	160	129	116	128	109	98	89	
15:00-16:00	127	91	97	102	114	99	74	
16:00-17:00	123	88	90	129	108	97	68	
17:00-18:00	139	80	102	110	103	68	59	
18:00-19:00	88	65	56	59	70	63	60	
19:00-20:00	85	52	59	70	73	58	46	
20:00-21:00	51	23	45	45	52	39	37	
21:00-22:00	35	21	30	52	32	23	50	
22:00-23:00	16	16	22	30	20	20	16	
23:00-24:00	7	8	10	7	15	19	14	
<b>PM Total</b>	<b>1,091</b>	<b>780</b>	<b>836</b>	<b>943</b>	<b>934</b>	<b>812</b>	<b>688</b>	<b>0</b>
<b>24 Hr. Total</b>	<b>1,091</b>	<b>1,848</b>	<b>1,857</b>	<b>1,932</b>	<b>1,862</b>	<b>1,797</b>	<b>1,060</b>	<b>282</b>
Noon - Noon	2,159	1,801	1,825	1,871	1,919	1,184	970	
	ADT 1,676	AWD 1,854	AADT	AAWD	SADT	SAWDT	WADT	DHV



## Appendix A-4

### Highway 417 ATR Counts







Engineering

Software

# Weekly Volume Summary

Mon, Apr 18, 2011

**Location:** Hwy 417 - 1.2 km West of Terry Fox Dr IC140**LHRS/Offset:** 49560 / 0.0**Region:** Eastern**Pattern Type:** Commuter**PCS#:** 90**Hwy. TVIS#:** 417220**Count Direction:** EB**Report Dates:** Jul 2, 2009 to Jul 8, 2009

Hour Interval	Thu 09/07/02	Fri 3	Sat 4	Sun 5	Mon 6	Tue 7	Wed 8	Thu 9
0:00- 1:00		121	171	246	180	106	88	106
1:00- 2:00		88	95	170	80	70	74	88
2:00- 3:00		69	71	67	71	67	67	84
3:00- 4:00		77	51	51	66	84	54	111
4:00- 5:00		157	86	58	148	143	153	155
5:00- 6:00		648	168	135	923	844	893	850
6:00- 7:00		2,097	414	264	2,715	2,478	2,645	2,645
7:00- 8:00		2,257	541	343	2,850	2,428	2,830	2,785
8:00- 9:00		1,957	843	505	2,259	2,048	2,338	2,249
9:00-10:00		1,860	1,153	946	1,866	1,734	1,870	2,305
10:00-11:00		1,832	1,514	1,235	1,625	1,680	1,687	2,414
11:00-12:00		1,946	1,704	1,455	1,593	1,693	1,650	2,439
<b>AM Total</b>	<b>0</b>	<b>13,109</b>	<b>6,811</b>	<b>5,475</b>	<b>14,376</b>	<b>13,375</b>	<b>14,349</b>	<b>16,231</b>
12:00-13:00	1,804	1,846	1,687	1,761	1,686	1,666	1,602	
13:00-14:00	1,700	1,794	1,776	1,898	1,551	1,563	1,476	
14:00-15:00	1,716	1,760	1,791	2,128	1,749	1,580	1,540	
15:00-16:00	1,741	1,697	1,601	2,346	1,650	1,516	1,712	
16:00-17:00	1,745	1,773	1,541	2,628	1,736	1,623	1,802	
17:00-18:00	1,697	1,599	1,409	2,377	1,730	1,591	1,783	
18:00-19:00	1,301	1,398	1,067	2,251	1,319	1,254	1,467	
19:00-20:00	1,015	1,079	1,008	2,121	922	882	1,024	
20:00-21:00	755	784	898	2,082	705	690	868	
21:00-22:00	600	661	872	1,396	578	585	590	
22:00-23:00	361	463	641	777	355	383	477	
23:00-24:00	231	285	461	359	196	178	246	
<b>PM Total</b>	<b>14,666</b>	<b>15,139</b>	<b>14,752</b>	<b>22,124</b>	<b>14,177</b>	<b>13,511</b>	<b>14,587</b>	<b>0</b>
<b>24 Hr. Total</b>	<b>14,666</b>	<b>28,248</b>	<b>21,563</b>	<b>27,599</b>	<b>28,553</b>	<b>26,886</b>	<b>28,936</b>	<b>16,231</b>
<b>Noon - Noon</b>	<b>27,775</b>	<b>21,950</b>	<b>20,227</b>	<b>36,500</b>	<b>27,552</b>	<b>27,860</b>	<b>30,818</b>	



Engineering

Software

# Weekly Volume Summary

Mon, Apr 18, 2011

**Location:** Hwy 417 - 1.2 km West of Terry Fox Dr IC140

**LHRS/Offset:** 49560 / 0.0

**Region:** Eastern

**Pattern Type:** Commuter

**PCS#:** 90

**Hwy. TVIS#:** 417220

**Count Direction:** WB

**Report Dates:** Jul 2, 2009 to Jul 8, 2009

Hour Interval	Thu 09/07/02	Fri 3	Sat 4	Sun 5	Mon 6	Tue 7	Wed 8	Thu 9
0:00- 1:00		237	352	367	171	180	185	261
1:00- 2:00		109	170	164	85	111	130	114
2:00- 3:00		84	140	142	57	81	78	101
3:00- 4:00		65	87	63	66	64	68	93
4:00- 5:00		102	101	64	112	99	103	105
5:00- 6:00		271	191	120	347	323	300	336
6:00- 7:00		828	471	372	940	864	1,009	859
7:00- 8:00		1,233	787	555	1,311	1,160	1,303	1,291
8:00- 9:00		1,215	1,261	772	1,303	1,146	1,354	1,215
9:00-10:00		1,436	1,716	1,164	1,307	1,156	1,321	1,258
10:00-11:00		1,650	1,929	1,281	1,148	1,133	1,239	1,299
11:00-12:00		1,810	2,096	1,699	1,354	1,405	1,492	1,323
<b>AM Total</b>	<b>0</b>	<b>9,040</b>	<b>9,301</b>	<b>6,763</b>	<b>8,201</b>	<b>7,722</b>	<b>8,582</b>	<b>8,255</b>
12:00-13:00	1,554	2,039	1,854	1,817	1,470	1,583	970	
13:00-14:00	1,768	2,097	1,877	1,852	1,508	1,569	1,434	
14:00-15:00	2,028	2,338	1,614	1,731	1,535	1,891	1,869	
15:00-16:00	2,314	2,689	1,243	1,539	2,393	2,414	2,541	
16:00-17:00	2,747	2,970	1,682	1,529	3,066	2,993	3,216	
17:00-18:00	2,428	2,761	1,272	1,351	2,687	2,832	2,842	
18:00-19:00	1,846	2,322	1,167	963	1,689	1,866	1,672	
19:00-20:00	1,341	1,634	912	918	797	1,281	1,282	
20:00-21:00	1,138	1,174	756	530	978	1,071	1,212	
21:00-22:00	975	1,008	737	723	845	1,007	957	
22:00-23:00	547	635	568	440	515	557	630	
23:00-24:00	380	479	475	285	300	369	497	
<b>PM Total</b>	<b>19,066</b>	<b>22,146</b>	<b>14,157</b>	<b>13,678</b>	<b>17,783</b>	<b>19,433</b>	<b>19,122</b>	<b>0</b>
<b>24 Hr. Total</b>	<b>19,066</b>	<b>31,186</b>	<b>23,458</b>	<b>20,441</b>	<b>25,984</b>	<b>27,155</b>	<b>27,704</b>	<b>8,255</b>
<b>Noon - Noon</b>	<b>28,106</b>	<b>31,447</b>	<b>20,920</b>	<b>21,879</b>	<b>25,505</b>	<b>28,015</b>	<b>27,377</b>	





Engineering

Software

# Weekly Volume Summary

Mon, Apr 18, 2011

**Location:** Hwy 417 - 1.2 km West of Terry Fox Dr IC140**LHRS/Offset:** 49560 / 0.0**Region:** Eastern**Pattern Type:** Commuter**PCS#:** 90**Hwy. TVIS#:** 417220**Count Direction:** EB/WB**Report Dates:** Jul 2, 2009 to Jul 8, 2009

Hour Interval	Thu 09/07/02	Fri 3	Sat 4	Sun 5	Mon 6	Tue 7	Wed 8	Thu 9
0:00- 1:00		358	523	613	351	286	273	367
1:00- 2:00		197	265	334	165	181	204	202
2:00- 3:00		153	211	209	128	148	145	185
3:00- 4:00		142	138	114	132	148	122	204
4:00- 5:00		259	187	122	260	242	256	260
5:00- 6:00		919	359	255	1,270	1,167	1,193	1,186
6:00- 7:00		2,925	885	636	3,655	3,342	3,654	3,504
7:00- 8:00		3,490	1,328	898	4,161	3,588	4,133	4,076
8:00- 9:00		3,172	2,104	1,277	3,562	3,194	3,692	3,464
9:00-10:00		3,296	2,869	2,110	3,173	2,890	3,191	3,563
10:00-11:00		3,482	3,443	2,516	2,773	2,813	2,926	3,713
11:00-12:00		3,756	3,800	3,154	2,947	3,098	3,142	3,762
<b>AM Total</b>	<b>0</b>	<b>22,149</b>	<b>16,112</b>	<b>12,238</b>	<b>22,577</b>	<b>21,097</b>	<b>22,931</b>	<b>24,486</b>
12:00-13:00	3,358	3,885	3,541	3,578	3,156	3,249	2,572	
13:00-14:00	3,468	3,891	3,653	3,750	3,059	3,132	2,910	
14:00-15:00	3,744	4,098	3,405	3,859	3,284	3,471	3,409	
15:00-16:00	4,055	4,386	2,844	3,885	4,043	3,930	4,253	
16:00-17:00	4,492	4,743	3,223	4,157	4,802	4,616	5,018	
17:00-18:00	4,125	4,360	2,681	3,728	4,417	4,423	4,625	
18:00-19:00	3,147	3,720	2,234	3,214	3,008	3,120	3,139	
19:00-20:00	2,356	2,713	1,920	3,039	1,719	2,163	2,306	
20:00-21:00	1,893	1,958	1,654	2,612	1,683	1,761	2,080	
21:00-22:00	1,575	1,669	1,609	2,119	1,423	1,592	1,547	
22:00-23:00	908	1,098	1,209	1,217	870	940	1,107	
23:00-24:00	611	764	936	644	496	547	743	
<b>PM Total</b>	<b>33,732</b>	<b>37,285</b>	<b>28,909</b>	<b>35,802</b>	<b>31,960</b>	<b>32,944</b>	<b>33,709</b>	<b>0</b>
<b>24 Hr. Total</b>	<b>33,732</b>	<b>59,434</b>	<b>45,021</b>	<b>48,040</b>	<b>54,537</b>	<b>54,041</b>	<b>56,640</b>	<b>24,486</b>
<b>Noon - Noon</b>	<b>55,881</b>	<b>53,397</b>	<b>41,147</b>	<b>58,379</b>	<b>53,057</b>	<b>55,875</b>	<b>58,195</b>	
<b>ADT</b>	<b>53,704</b>	<b>55,752</b>	<b>47,260</b>	<b>49,620</b>	<b>52,458</b>	<b>55,574</b>	<b>42,534</b>	<b>4,442</b>
<b>AWD</b>								
<b>AADT</b>								
<b>AAWD</b>								
<b>SADT</b>								
<b>SAWDT</b>								
<b>WADT</b>								
<b>DHV</b>								

# Weekly Volume Summary

Tue, Apr 19, 2011

**Location:** Hwy 7 - 1.2 km West of Hwy 417 IC

**LHRS/Offset:** 14024 / 0.0

**Region:** Eastern

**Pattern Type:** Commuter

**PCS#:** 90

**Hwy. TVIS#:** 7010

**Count Direction:** EB

**Report Dates:** Mar 30, 2009 to Apr 5, 2009

Hour Interval	Mon 09/03/30	Tue 31	Wed 1	Thu 2	Fri 3	Sat 4	Sun 5	Mon 6
0:00- 1:00		23	31	31	30	27	29	17
1:00- 2:00		43	28	26	37	23	20	22
2:00- 3:00		35	32	35	39	19	9	18
3:00- 4:00		50	47	46	53	19	11	39
4:00- 5:00		249	245	256	216	57	27	252
5:00- 6:00		741	691	720	632	98	69	734
6:00- 7:00		803	832	853	802	133	82	809
7:00- 8:00		635	672	719	635	275	148	678
8:00- 9:00		495	476	494	464	354	228	442
9:00-10:00		353	364	390	373	474	332	340
10:00-11:00		331	390	360	373	452	386	336
11:00-12:00		329	307	345	371	496	413	313
AM Total	0	4,087	4,115	4,275	4,025	2,427	1,754	4,000
12:00-13:00	333	303	321	336	393	500	437	
13:00-14:00	333	340	309	338	350	458	450	
14:00-15:00	326	339	341	345	398	409	437	
15:00-16:00	309	300	294	310	373	431	438	
16:00-17:00	331	307	313	373	354	413	378	
17:00-18:00	298	266	267	300	380	464	329	
18:00-19:00	191	166	178	221	258	247	296	
19:00-20:00	121	121	132	162	161	171	250	
20:00-21:00	90	129	122	153	161	173	188	
21:00-22:00	87	77	84	105	137	165	128	
22:00-23:00	55	46	60	64	65	84	72	
23:00-24:00	27	32	40	34	42	53	23	
PM Total	2,501	2,426	2,461	2,741	3,072	3,568	3,426	0
24 Hr. Total	2,501	6,513	6,576	7,016	7,097	5,995	5,180	4,000
Noon - Noon	6,588	6,541	6,736	6,766	5,499	5,322	7,426	

WB data not good.

# Weekly Volume Summary

Tue, Apr 19, 2011

**Location:** Hwy 7 - 1.2 km West of Hwy 417 IC

**LHRS/Offset:** 14024 / 0.0

**Region:** Eastern

**Pattern Type:** Commuter

**PCS#:** 90

**Hwy. TVIS#:** 7010

**Count Direction:** EB

**Report Dates:** Jul 23, 2009 to Jul 29, 2009

Hour Interval	Thu 09/07/23	Fri 24	Sat 25	Sun 26	Mon 27	Tue 28	Wed 29	Thu 30
0:00- 1:00		33	62	73	64	33	27	42
1:00- 2:00		31	38	37	380	34	34	37
2:00- 3:00		31	21	15	1,018	31	29	25
3:00- 4:00		38	15	13	1,365	39	43	38
4:00- 5:00		54	22	12	1,603	68	59	59
5:00- 6:00		241	54	35	1,217	274	277	253
6:00- 7:00		654	118	81	1,202	724	718	695
7:00- 8:00		707	154	97	1,081	746	694	774
8:00- 9:00		605	245	187	598	598	568	602
9:00-10:00		498	313	232	456	449	479	452
10:00-11:00		437	386	397	372	429	391	355
11:00-12:00		474	437	504	431	365	409	427
AM Total	0	3,803	1,865	1,683	9,787	3,790	3,728	3,759
12:00-13:00	460	477	499	515	291	364	480	
13:00-14:00	461	448	475	552	273	379	361	
14:00-15:00	461	461	478	341	440	366	435	
15:00-16:00	413	459	433	423	362	384	440	
16:00-17:00	412	404	476	441	378	346	401	
17:00-18:00	381	431	556	618	346	386	373	
18:00-19:00	307	387	268	563	347	332	355	
19:00-20:00	234	319	234	484	264	256	262	
20:00-21:00	235	226	188	456	231	230	259	
21:00-22:00	154	220	245	336	183	221	220	
22:00-23:00	124	138	185	203	129	103	168	
23:00-24:00	57	92	113	109	55	59	116	
PM Total	3,699	4,062	4,150	5,041	3,299	3,426	3,870	0
24 Hr. Total	3,699	7,865	6,015	6,724	13,086	7,216	7,598	3,759
Noon - Noon	7,502	5,927	5,833	14,828	7,089	7,154	7,629	

WB data not good.

# Weekly Volume Summary

Tue, Apr 19, 2011

**Location:** Hwy 7 - 1.2 km West of Hwy 417 IC

**LHRS/Offset:** 14024 / 0.0

**Region:** Eastern

**Pattern Type:** Commuter

**PCS#:** 90

**Hwy. TVIS#:** 7010

**Count Direction:** WB

**Report Dates:** Sep 21, 2009 to Sep 27, 2009

Hour Interval	Mon 09/09/21	Tue 22	Wed 23	Thu 24	Fri 25	Sat 26	Sun 27	Mon 28
0:00- 1:00		28	31	33	44	59	81	28
1:00- 2:00		30	26	23	33	33	39	29
2:00- 3:00		28	30	33	28	27	24	24
3:00- 4:00		33	34	32	41	25	14	28
4:00- 5:00		63	73	75	59	29	14	54
5:00- 6:00		279	311	302	269	46	32	297
6:00- 7:00		854	820	815	784	137	84	822
7:00- 8:00		868	854	914	848	170	105	952
8:00- 9:00		670	674	667	646	268	155	684
9:00-10:00		436	508	480	454	370	273	475
10:00-11:00		408	426	446	430	460	385	418
11:00-12:00		383	433	426	419	490	464	413
AM Total	0	4,080	4,220	4,246	4,055	2,114	1,670	4,224
12:00-13:00	408	372	366	375	419	493	553	
13:00-14:00	361	358	354	376	431	478	552	
14:00-15:00	426	388	378	411	477	506	546	
15:00-16:00	402	343	334	432	477	530	609	
16:00-17:00	435	389	405	430	520	564	565	
17:00-18:00	413	394	365	374	489	477	501	
18:00-19:00	316	311	318	366	555	451	408	
19:00-20:00	212	209	195	276	385	333	346	
20:00-21:00	172	145	160	232	264	257	323	
21:00-22:00	102	114	109	146	187	220	187	
22:00-23:00	85	91	97	104	190	184	136	
23:00-24:00	47	42	50	65	119	147	71	
PM Total	3,379	3,156	3,131	3,587	4,513	4,640	4,797	0
24 Hr. Total	3,379	7,236	7,351	7,833	8,568	6,754	6,467	4,224
Noon - Noon	7,459	7,376	7,377	7,642	6,627	6,310	9,021	

EB data not good.



Engineering

Software

# Weekly Volume Summary

Mon, Apr 18, 2011

**Location:** Hwy 417 - 3.4 km West of Hwy 7 IC145

**LHRS/Offset:** 49590 / 0.0

**Region:** Eastern

**Pattern Type:** Intermediate Recreation

**PCS#:** 43

**Hwy. TVIS#:** 417240

**Count Direction:** EB

**Report Dates:** Sep 18, 2009 to Sep 24, 2009

Hour Interval	Fri 09/09/18	Sat 19	Sun 20	Mon 21	Tue 22	Wed 23	Thu 24	Fri 25
0:00- 1:00		72	62	106	80	32	34	53
1:00- 2:00		43	62	54	40	31	34	30
2:00- 3:00		28	33	27	21	27	25	35
3:00- 4:00		34	31	26	36	40	26	43
4:00- 5:00		99	34	29	85	85	85	79
5:00- 6:00		449	88	70	497	497	515	510
6:00- 7:00		1,318	229	204	1,440	1,446	1,464	1,447
7:00- 8:00		1,410	305	193	1,541	1,554	1,529	1,522
8:00- 9:00		995	514	296	1,037	968	955	1,034
9:00-10:00		886	677	587	778	841	869	890
10:00-11:00		779	729	658	710	612	731	667
11:00-12:00		715	774	846	625	694	800	651
<b>AM Total</b>	<b>0</b>	<b>6,828</b>	<b>3,538</b>	<b>3,096</b>	<b>6,890</b>	<b>6,827</b>	<b>7,067</b>	<b>6,961</b>
12:00-13:00	626	740	862	942	587	604	655	
13:00-14:00	672	740	922	1,054	702	616	589	
14:00-15:00	752	813	810	1,090	684	619	626	
15:00-16:00	851	839	851	1,229	752	667	653	
16:00-17:00	804	856	794	1,335	724	677	630	
17:00-18:00	796	870	814	1,302	665	688	615	
18:00-19:00	687	861	701	1,166	562	539	524	
19:00-20:00	511	690	647	1,133	427	344	393	
20:00-21:00	354	453	474	881	295	254	241	
21:00-22:00	279	344	350	522	195	188	174	
22:00-23:00	186	229	286	252	155	148	145	
23:00-24:00	92	136	151	163	81	96	93	
<b>PM Total</b>	<b>6,610</b>	<b>7,571</b>	<b>7,662</b>	<b>11,069</b>	<b>5,829</b>	<b>5,440</b>	<b>5,338</b>	<b>0</b>
<b>24 Hr. Total</b>	<b>6,610</b>	<b>14,399</b>	<b>11,200</b>	<b>14,165</b>	<b>12,719</b>	<b>12,267</b>	<b>12,405</b>	<b>6,961</b>
<b>Noon - Noon</b>	<b>13,438</b>	<b>11,109</b>	<b>10,758</b>	<b>17,959</b>	<b>12,656</b>	<b>12,507</b>	<b>12,299</b>	



Engineering

Software

# Weekly Volume Summary

Mon, Apr 18, 2011

**Location:** Hwy 417 - 3.4 km West of Hwy 7 IC145**LHRS/Offset:** 49590 / 0.0**Region:** Eastern**Pattern Type:** Intermediate Recreation**PCS#:** 43**Hwy. TVIS#:** 417240**Count Direction:** WB**Report Dates:** Sep 18, 2009 to Sep 24, 2009

Hour Interval	Fri 09/09/18	Sat 19	Sun 20	Mon 21	Tue 22	Wed 23	Thu 24	Fri 25
0:00- 1:00		125	156	142	79	80	87	86
1:00- 2:00		59	90	68	29	49	53	50
2:00- 3:00		57	66	52	24	40	40	41
3:00- 4:00		55	65	33	32	36	43	35
4:00- 5:00		59	36	24	57	55	41	38
5:00- 6:00		149	85	56	134	110	124	136
6:00- 7:00		349	213	129	396	347	397	407
7:00- 8:00		496	454	263	487	421	494	548
8:00- 9:00		530	624	419	538	490	532	523
9:00-10:00		647	834	588	603	497	529	573
10:00-11:00		721	912	782	593	499	541	581
11:00-12:00		813	944	829	619	576	539	563
AM Total	0	4,060	4,479	3,385	3,591	3,200	3,420	3,581
12:00-13:00	637	849	913	964	620	560	637	
13:00-14:00	707	971	853	994	633	628	630	
14:00-15:00	855	1,226	844	937	751	746	768	
15:00-16:00	1,295	1,567	867	897	1,111	1,210	1,161	
16:00-17:00	1,521	1,773	788	873	1,549	1,463	1,466	
17:00-18:00	1,313	1,621	710	719	1,338	1,356	1,358	
18:00-19:00	1,010	1,352	576	571	763	777	798	
19:00-20:00	700	914	423	526	524	504	546	
20:00-21:00	516	595	398	429	441	481	455	
21:00-22:00	407	525	497	278	356	375	386	
22:00-23:00	297	342	337	204	193	281	261	
23:00-24:00	303	268	207	150	128	150	161	
PM Total	9,561	12,003	7,413	7,542	8,407	8,531	8,627	0
24 Hr. Total	9,561	16,063	11,892	10,927	11,998	11,731	12,047	3,581
Noon - Noon	13,621	16,482	10,798	11,133	11,607	11,951	12,208	



Engineering

Software

# Weekly Volume Summary

Mon, Apr 18, 2011

**Location:** Hwy 417 - 3.4 km West of Hwy 7 IC145**LHRS/Offset:** 49590 / 0.0**Region:** Eastern**Pattern Type:** Intermediate Recreation**PCS#:** 43**Hwy. TVIS#:** 417240**Count Direction:** EB/WB**Report Dates:** Sep 18, 2009 to Sep 24, 2009

Hour Interval	Fri 09/09/18	Sat 19	Sun 20	Mon 21	Tue 22	Wed 23	Thu 24	Fri 25
0:00- 1:00		197	218	248	159	112	121	139
1:00- 2:00		102	152	122	69	80	87	80
2:00- 3:00		85	99	79	45	67	65	76
3:00- 4:00		89	96	59	68	76	69	78
4:00- 5:00		158	70	53	142	140	126	117
5:00- 6:00		598	173	126	631	607	639	646
6:00- 7:00		1,667	442	333	1,836	1,793	1,861	1,854
7:00- 8:00		1,906	759	456	2,028	1,975	2,023	2,070
8:00- 9:00		1,525	1,138	715	1,575	1,458	1,487	1,557
9:00-10:00		1,533	1,511	1,175	1,381	1,338	1,398	1,463
10:00-11:00		1,500	1,641	1,440	1,303	1,111	1,272	1,248
11:00-12:00		1,528	1,718	1,675	1,244	1,270	1,339	1,214
AM Total	0	10,888	8,017	6,481	10,481	10,027	10,487	10,542
12:00-13:00	1,263	1,589	1,775	1,906	1,207	1,164	1,292	
13:00-14:00	1,379	1,711	1,775	2,048	1,335	1,244	1,219	
14:00-15:00	1,607	2,039	1,654	2,027	1,435	1,365	1,394	
15:00-16:00	2,146	2,406	1,718	2,126	1,863	1,877	1,814	
16:00-17:00	2,325	2,629	1,582	2,208	2,273	2,140	2,096	
17:00-18:00	2,109	2,491	1,524	2,021	2,003	2,044	1,973	
18:00-19:00	1,697	2,213	1,277	1,737	1,325	1,316	1,322	
19:00-20:00	1,211	1,604	1,070	1,659	951	848	939	
20:00-21:00	870	1,048	872	1,310	736	735	696	
21:00-22:00	686	869	847	800	551	563	560	
22:00-23:00	483	571	623	456	348	429	406	
23:00-24:00	395	404	358	313	209	246	254	
PM Total	16,171	19,574	15,075	18,611	14,236	13,971	13,965	0
24 Hr. Total	16,171	30,462	23,092	25,092	24,717	23,998	24,452	10,542
Noon - Noon	27,059	27,591	21,556	29,092	24,263	24,458	24,507	
ADT	25,504	AWD	AADT	AAWD	SADT	SAWDT	WADT	DHIV
		25,580	24,994	27,115	30,242	29,555	21,245	2,999



Engineering

Software

# Weekly Volume Summary

Mon, Apr 18, 2011

**Location:** Hwy 417 - 3.4 km West of Hwy 7 IC145

**LHRS/Offset:** 49590 / 0.0

**Region:** Eastern

**Pattern Type:** Intermediate Recreation

**PCS#:** 43

**Hwy. TVIS#:** 417240

**Count Direction:** EB

**Report Dates:** Mar 23, 2009 to Mar 29, 2009

Hour Interval	Mon 09/03/23	Tue 24	Wed 25	Thu 26	Fri 27	Sat 28	Sun 29	Mon 30
0:00- 1:00		45	31	39	44	65	82	41
1:00- 2:00		26	20	28	53	31	41	25
2:00- 3:00		18	23	28	32	25	32	18
3:00- 4:00		35	22	38	41	25	21	32
4:00- 5:00		66	75	69	81	40	31	78
5:00- 6:00		485	472	493	415	72	58	439
6:00- 7:00		1,412	1,465	1,458	1,316	235	151	1,424
7:00- 8:00		1,410	1,356	1,407	1,271	355	167	1,341
8:00- 9:00		955	978	923	924	564	285	860
9:00-10:00		755	764	815	772	624	464	687
10:00-11:00		654	628	684	738	694	688	558
11:00-12:00		608	588	603	701	735	819	529
<b>AM Total</b>	<b>0</b>	<b>6,469</b>	<b>6,422</b>	<b>6,585</b>	<b>6,388</b>	<b>3,465</b>	<b>2,839</b>	<b>6,032</b>
12:00-13:00	563	567	615	603	671	778	853	
13:00-14:00	580	511	561	614	669	752	943	
14:00-15:00	608	575	555	621	748	811	933	
15:00-16:00	621	563	569	644	761	766	907	
16:00-17:00	599	622	601	732	834	817	866	
17:00-18:00	548	569	618	661	869	776	798	
18:00-19:00	410	434	449	548	741	749	713	
19:00-20:00	266	305	275	368	447	506	574	
20:00-21:00	146	273	219	318	364	416	457	
21:00-22:00	135	176	185	231	318	308	306	
22:00-23:00	172	131	126	193	212	238	176	
23:00-24:00	89	75	75	102	122	123	102	
<b>PM Total</b>	<b>4,737</b>	<b>4,801</b>	<b>4,848</b>	<b>5,635</b>	<b>6,756</b>	<b>7,040</b>	<b>7,628</b>	<b>0</b>
<b>24 Hr. Total</b>	<b>4,737</b>	<b>11,270</b>	<b>11,270</b>	<b>12,220</b>	<b>13,144</b>	<b>10,505</b>	<b>10,467</b>	<b>6,032</b>
<b>Noon - Noon</b>	<b>11,206</b>	<b>11,223</b>	<b>11,433</b>	<b>12,023</b>	<b>10,221</b>	<b>9,879</b>	<b>13,660</b>	





Engineering  
Software

# Weekly Volume Summary

Mon, Apr 18, 2011

**Location:** Hwy 417 - 3.4 km West of Hwy 7 IC145

**LHRS/Offset:** 49590 / 0.0

**Region:** Eastern

**Pattern Type:** Intermediate Recreation

**PCS#:** 43

**Hwy. TVIS#:** 417240

**Count Direction:** WB

**Report Dates:** Mar 23, 2009 to Mar 29, 2009

Hour Interval	Mon 09/03/23	Tue 24	Wed 25	Thu 26	Fri 27	Sat 28	Sun 29	Mon 30
0:00- 1:00		112	96	99	93	171	155	77
1:00- 2:00		43	66	60	64	102	91	34
2:00- 3:00		59	57	58	46	66	50	26
3:00- 4:00		41	44	25	56	61	39	30
4:00- 5:00		50	38	35	51	61	19	46
5:00- 6:00		114	114	105	104	59	37	119
6:00- 7:00		254	240	246	233	134	78	245
7:00- 8:00		424	409	403	416	224	140	431
8:00- 9:00		478	486	434	462	453	246	423
9:00-10:00		422	461	445	498	644	370	402
10:00-11:00		460	435	440	531	680	525	409
11:00-12:00		495	493	408	617	801	571	437
AM Total	0	2,952	2,939	2,758	3,171	3,456	2,321	2,679
12:00-13:00	469	497	534	532	648	766	739	
13:00-14:00	517	549	533	548	739	761	796	
14:00-15:00	624	683	666	755	884	703	767	
15:00-16:00	1,069	1,051	1,027	1,091	1,091	737	757	
16:00-17:00	1,338	1,366	1,402	1,376	1,380	724	748	
17:00-18:00	1,264	1,290	1,277	1,236	1,324	740	595	
18:00-19:00	706	775	735	787	911	508	480	
19:00-20:00	430	450	482	511	582	412	385	
20:00-21:00	327	453	429	458	548	384	295	
21:00-22:00	338	382	428	510	507	393	205	
22:00-23:00	408	237	254	288	330	247	139	
23:00-24:00	321	160	158	172	259	230	104	
PM Total	7,811	7,893	7,925	8,264	9,203	6,605	6,010	0
24 Hr. Total	7,811	10,845	10,864	11,022	12,374	10,061	8,331	2,679
Noon - Noon	10,763	10,832	10,683	11,435	12,659	8,926	8,689	



Engineering

Software

# Weekly Volume Summary

Mon, Apr 18, 2011

**Location:** Hwy 417 - 3.4 km West of Hwy 7 IC145**LHRS/Offset:** 49590 / 0.0**Region:** Eastern**Pattern Type:** Intermediate Recreation**PCS#:** 43**Hwy. TVIS#:** 417240**Count Direction:** EB/WB**Report Dates:** Mar 23, 2009 to Mar 29, 2009

Hour Interval	Mon 09/03/23	Tue 24	Wed 25	Thu 26	Fri 27	Sat 28	Sun 29	Mon 30
0:00- 1:00		157	127	138	137	236	237	118
1:00- 2:00		69	86	88	117	133	132	59
2:00- 3:00		77	80	86	78	91	82	44
3:00- 4:00		76	66	63	97	86	60	62
4:00- 5:00		116	113	104	132	101	50	124
5:00- 6:00		599	586	598	519	131	95	558
6:00- 7:00		1,666	1,705	1,704	1,549	369	229	1,669
7:00- 8:00		1,834	1,765	1,810	1,687	579	307	1,772
8:00- 9:00		1,433	1,464	1,357	1,386	1,017	531	1,283
9:00-10:00		1,177	1,225	1,260	1,270	1,268	834	1,089
10:00-11:00		1,114	1,063	1,124	1,269	1,374	1,213	967
11:00-12:00		1,103	1,081	1,011	1,318	1,536	1,390	966
AM Total	0	9,421	9,361	9,343	9,559	6,921	5,160	8,711
12:00-13:00	1,032	1,064	1,149	1,135	1,319	1,544	1,592	
13:00-14:00	1,097	1,060	1,094	1,162	1,408	1,513	1,739	
14:00-15:00	1,232	1,258	1,221	1,376	1,632	1,514	1,700	
15:00-16:00	1,690	1,614	1,596	1,735	1,852	1,503	1,664	
16:00-17:00	1,937	1,988	2,003	2,108	2,214	1,541	1,614	
17:00-18:00	1,812	1,859	1,895	1,897	2,193	1,516	1,393	
18:00-19:00	1,116	1,209	1,184	1,335	1,652	1,257	1,193	
19:00-20:00	696	755	757	879	1,029	918	959	
20:00-21:00	473	726	648	776	912	800	752	
21:00-22:00	473	558	613	741	825	701	511	
22:00-23:00	580	368	380	481	542	485	315	
23:00-24:00	410	235	233	274	381	353	206	
PM Total	12,548	12,694	12,773	13,899	15,959	13,645	13,638	0
24 Hr. Total	12,548	22,115	22,134	23,242	25,518	20,566	18,798	8,711
Noon - Noon	21,969	22,055	22,116	23,458	22,880	18,805	22,349	
ADT	21,947	AWD	AADT	AAWD	SADT	SAWDT	WADT	DHV
		22,400	24,581	26,431	29,743	28,810	20,894	2,950



Engineering

Software

# Weekly Volume Summary

Mon, Apr 18, 2011

**Location:** Hwy 417 - 3.4 km West of Hwy 7 IC145**LHRS/Offset:** 49590 / 0.0**Region:** Eastern**Pattern Type:** Intermediate Recreation**PCS#:** 43**Hwy. TVIS#:** 417240**Count Direction:** EB**Report Dates:** Jul 10, 2009 to Jul 16, 2009

Hour Interval	Fri 09/07/10	Sat 11	Sun 12	Mon 13	Tue 14	Wed 15	Thu 16	Fri 17
0:00- 1:00		92	81	67	56	45	51	58
1:00- 2:00		55	52	28	24	23	39	27
2:00- 3:00		25	39	37	31	18	28	32
3:00- 4:00		22	26	22	35	34	32	48
4:00- 5:00		38	35	103	89	84	72	62
5:00- 6:00		92	69	557	504	494	517	447
6:00- 7:00		214	140	1,423	1,395	1,448	1,382	1,179
7:00- 8:00		316	174	1,328	1,330	1,328	1,336	1,214
8:00- 9:00		502	289	1,020	946	939	1,038	937
9:00-10:00		614	499	788	843	758	792	754
10:00-11:00		778	605	788	724	746	754	797
11:00-12:00		859	786	749	780	713	766	803
AM Total	0	3,607	2,795	6,910	6,757	6,630	6,807	6,358
12:00-13:00	754	907	930	768	659	666	727	
13:00-14:00	805	865	1,181	739	694	694	713	
14:00-15:00	839	873	1,330	790	762	792	790	
15:00-16:00	946	833	1,509	819	733	844	831	
16:00-17:00	990	655	1,683	839	770	865	827	
17:00-18:00	857	654	1,656	760	768	946	810	
18:00-19:00	788	579	1,540	608	647	750	631	
19:00-20:00	638	452	1,460	432	429	544	476	
20:00-21:00	569	421	1,183	358	404	468	419	
21:00-22:00	405	414	724	284	336	356	341	
22:00-23:00	330	270	379	190	212	241	241	
23:00-24:00	180	165	182	76	117	111	138	
PM Total	8,101	7,088	13,757	6,663	6,531	7,277	6,944	0
24 Hr. Total	8,101	10,695	16,552	13,573	13,288	13,907	13,751	6,358
Noon - Noon	11,708	9,883	20,667	13,420	13,161	14,084	13,302	



Engineering  
Software

# Weekly Volume Summary

Mon, Apr 18, 2011

**Location:** Hwy 417 - 3.4 km West of Hwy 7 IC145

**L.HRS/Offset:** 49590 / 0.0

**Region:** Eastern

**Pattern Type:** Intermediate Recreation

**PCS#:** 43

**Hwy. TVIS#:** 417240

**Count Direction:** WB

**Report Dates:** Jul 10, 2009 to Jul 16, 2009

Hour Interval	Fri 09/07/10	Sat 11	Sun 12	Mon 13	Tue 14	Wed 15	Thu 16	Fri 17
0:00- 1:00		256	161	80	132	120	259	141
1:00- 2:00		113	102	46	67	53	82	61
2:00- 3:00		77	59	24	52	65	50	49
3:00- 4:00		58	48	34	42	49	30	61
4:00- 5:00		56	29	67	66	45	58	60
5:00- 6:00		90	71	162	130	143	144	144
6:00- 7:00		240	226	375	375	397	363	354
7:00- 8:00		414	334	521	532	517	563	604
8:00- 9:00		551	548	574	514	561	554	648
9:00-10:00		764	905	583	600	708	620	816
10:00-11:00		926	1,013	630	608	688	643	910
11:00-12:00		821	1,035	687	613	691	735	1,037
<b>AM Total</b>	<b>0</b>	<b>4,366</b>	<b>4,531</b>	<b>3,783</b>	<b>3,731</b>	<b>4,037</b>	<b>4,101</b>	<b>4,885</b>
12:00-13:00	1,021	916	1,164	632	662	702	753	
13:00-14:00	1,174	855	1,039	687	703	715	774	
14:00-15:00	1,278	864	887	780	850	853	912	
15:00-16:00	1,577	839	823	1,203	1,227	1,291	1,321	
16:00-17:00	1,792	799	732	1,450	1,468	1,524	1,599	
17:00-18:00	1,761	716	611	1,250	1,377	1,332	1,416	
18:00-19:00	1,366	573	577	831	860	884	949	
19:00-20:00	870	430	501	525	563	565	620	
20:00-21:00	553	363	392	486	547	512	625	
21:00-22:00	459	320	308	350	397	450	505	
22:00-23:00	375	341	200	220	264	266	290	
23:00-24:00	282	206	218	207	249	277	274	
<b>PM Total</b>	<b>12,508</b>	<b>7,222</b>	<b>7,452</b>	<b>8,621</b>	<b>9,167</b>	<b>9,371</b>	<b>10,038</b>	<b>0</b>
<b>24 Hr. Total</b>	<b>12,508</b>	<b>11,588</b>	<b>11,983</b>	<b>12,404</b>	<b>12,898</b>	<b>13,408</b>	<b>14,139</b>	<b>4,885</b>
<b>Noon - Noon</b>	<b>16,874</b>	<b>11,753</b>	<b>11,235</b>	<b>12,352</b>	<b>13,204</b>	<b>13,472</b>	<b>14,923</b>	



Engineering

Software

# Weekly Volume Summary

Mon, Apr 18, 2011

**Location:** Hwy 417 - 3.4 km West of Hwy 7 IC145**LHRS/Offset:** 49590 / 0.0**Region:** Eastern**Pattern Type:** Intermediate Recreation**PCS#:** 43**Hwy. TVIS#:** 417240**Count Direction:** EB/WB**Report Dates:** Jul 10, 2009 to Jul 16, 2009

Hour Interval	Fri 09/07/10	Sat 11	Sun 12	Mon 13	Tue 14	Wed 15	Thu 16	Fri 17
0:00- 1:00		348	242	147	188	165	310	199
1:00- 2:00		168	154	74	91	76	121	88
2:00- 3:00		102	98	61	83	83	78	81
3:00- 4:00		80	74	56	77	83	62	109
4:00- 5:00		94	64	170	155	129	130	122
5:00- 6:00		182	140	719	634	637	661	591
6:00- 7:00		454	366	1,798	1,770	1,845	1,745	1,533
7:00- 8:00		730	508	1,849	1,862	1,845	1,899	1,818
8:00- 9:00		1,053	837	1,594	1,460	1,500	1,592	1,585
9:00-10:00		1,378	1,404	1,371	1,443	1,466	1,412	1,570
10:00-11:00		1,704	1,618	1,418	1,332	1,434	1,397	1,707
11:00-12:00		1,680	1,821	1,436	1,393	1,404	1,501	1,840
<b>AM Total</b>	<b>0</b>	<b>7,973</b>	<b>7,326</b>	<b>10,693</b>	<b>10,488</b>	<b>10,667</b>	<b>10,908</b>	<b>11,243</b>
12:00-13:00	1,775	1,823	2,094	1,400	1,321	1,368	1,480	
13:00-14:00	1,979	1,720	2,220	1,426	1,397	1,409	1,487	
14:00-15:00	2,117	1,737	2,217	1,570	1,612	1,645	1,702	
15:00-16:00	2,523	1,672	2,332	2,022	1,960	2,135	2,152	
16:00-17:00	2,782	1,454	2,415	2,289	2,238	2,389	2,426	
17:00-18:00	2,618	1,370	2,267	2,010	2,145	2,278	2,226	
18:00-19:00	2,154	1,152	2,117	1,439	1,507	1,634	1,580	
19:00-20:00	1,508	882	1,961	957	992	1,109	1,096	
20:00-21:00	1,122	784	1,575	844	951	980	1,044	
21:00-22:00	864	734	1,032	634	733	806	846	
22:00-23:00	705	611	579	410	476	507	531	
23:00-24:00	462	371	400	283	366	388	412	
<b>PM Total</b>	<b>20,609</b>	<b>14,310</b>	<b>21,209</b>	<b>15,284</b>	<b>15,698</b>	<b>16,648</b>	<b>16,982</b>	<b>0</b>
<b>24 Hr. Total</b>	<b>20,609</b>	<b>22,283</b>	<b>28,535</b>	<b>25,977</b>	<b>26,186</b>	<b>27,315</b>	<b>27,890</b>	<b>11,243</b>
Noon - Noon	28,582	21,636	31,902	25,772	26,365	27,556	28,225	
	ADT 27,148	AWD 26,980	AADT 22,563	AAWD 24,938	SADT 27,301	SAWDT 27,182	WADT 19,178	DHV 2,708





**Appendix A-5**  
Carp Road and Richardson Side Road  
2011 ATR Counts







## Vehicle Classification Classes, Metric - Scheme F99

Class. #	Vehicle Type	No. of Axles	Axles 1 to 2 Spacing	Axles 2 to 3 Spacing	Axles 3 to 4 Spacing	Axles 4 to 5 Spacing	Axles 5 to 6 Spacing
	<b>Cars, Pickups, etc</b>						
1	Motorcycle	2	< 1.83				
2	Passenger Car	2	1.83 to 3.05				
	Pass. Car + trailer	3	< 3.05	3.05 to 5.49			
	Pass. Car + trailer	4	< 3.05		< 1.07		
3	Pickup	2	3.05 to 4.57				
	Pickup + trailer	3	3.05 to 4.57	3.05 to 5.49			
	Pickup + trailer	4	3.05 to 4.57		< 1.07		
	Pickup + trailer	5	3.02 to 4.57			< 1.07	
	<b>Buses, Dump Trucks, etc</b>						
4	Bus	2	> 6.10				
	Bus	3	> 5.80				
5	Single unit truck – dual rear axle	2	4.54 to 6.10			< 1.07	
6	3 axle Truck	3		< 5.49			
7	4 axle Truck	4					
	<b>Transports, etc</b>						
8	2 S 1	3		> 5.49			
	2 S 2	4		> 1.52	< 1.07		
	3 S 1	4		< 1.52	> 3.05		
9	3 S 2	5		< 1.86		1.07 to 2.44	
	5 axle combination	5					
10	6 axle combination	6			1.07 to 1.52		
	3 S 3	6					
11	2 S 1-2	5		> 1.83			
12	3 S 1-2	6					> 3.05
13	Truck	> 6					
14	Unclassified Vehicle						

**Carp Road, south of Hwy 417 EB on-ramp  
Monday, April 4, 2011**

\*\*\* = partial day count

Direction		Southbound				NorthBound				SB/NB	SB/NB
Classification Categories		1-3 cars	4-7 short trucks	8-14 long trucks	SB Vehs Total	1-3 cars	4-7 short trucks	8-14 long trucks	NB Vehs Total	All Vehs Total	All Trucks Total
Start	End										
0	0100	0	0	0	0	0	0	0	0	0	0
0100	0200	0	0	0	0	0	0	0	0	0	0
0200	0300	0	0	0	0	0	0	0	0	0	0
0300	0400	0	0	0	0	0	0	0	0	0	0
0400	0500	0	0	0	0	0	0	0	0	0	0
0500	0600	0	0	0	0	0	0	0	0	0	0
0600	0700	0	0	0	0	0	0	0	0	0	0
0700	0800	0	0	0	0	0	0	0	0	0	0
0800	0900	0	0	0	0	0	0	0	0	0	0
0900	1000	0	0	0	0	0	0	0	0	0	0
1000	1100	0	0	0	0	0	0	0	0	0	0
1100	1200	0	0	0	0	0	0	0	0	0	0
1200	1300	483	51	2	536	446	48	2	496	1032	103
1300	1400	443	55	3	501	482	60	6	548	1049	124
1400	1500	523	55	9	587	428	45	4	477	1064	113
1500	1600	763	54	5	822	581	52	6	639	1461	117
1600	1700	914	48	0	962	721	64	7	792	1754	119
1700	1800	981	37	1	1019	671	34	0	705	1724	72
1800	1900	591	10	0	601	432	10	1	443	1044	21
1900	2000	390	5	1	396	303	6	1	310	706	13
2000	2100	290	5	0	295	208	5	1	214	509	11
2100	2200	274	3	0	277	164	4	0	168	445	7
2200	2300	134	2	0	136	88	2	0	90	226	4
2300	2400	66	1	0	67	65	1	1	67	134	3
AM total		0	0	0	0	0	0	0	0	0	0
PM total		5852	326	21	6199	4589	331	29	4949	11148	707
*** 24Hr Total		5852	326	21	<b>6199</b>	4589	331	29	<b>4949</b>	<b>11148</b>	<b>707</b>
% of Total		94.4	5.3	0.3		92.7	6.7	0.6			<b>6.3</b>

source: Ritchie Traffic Services 613-540-4481

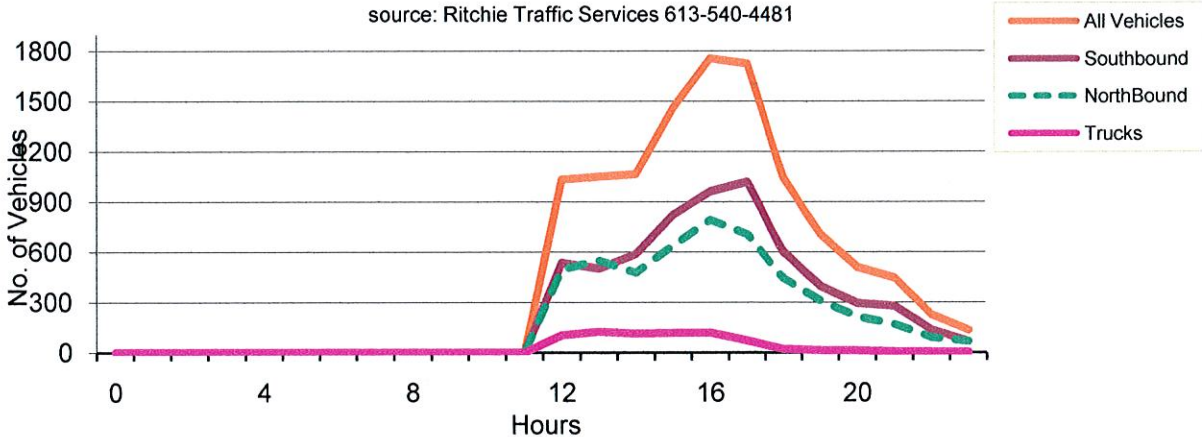

**Carp Road, south of Hwy 417 EB on-ramp  
Tuesday, April 5, 2011**

Direction		Southbound				NorthBound				SB/NB	SB/NB
Classification Categories		1-3 cars	4-7 short trucks	8-14 long trucks	SB Vehs Total	1-3 cars	4-7 short trucks	8-14 long trucks	NB Vehs Total	All Vehs Total	All Trucks Total
Start	End										
0	0100	47	3	1	51	18	1	0	19	70	5
0100	0200	29	1	1	31	17	0	0	17	48	2
0200	0300	11	0	0	11	8	3	0	11	22	3
0300	0400	16	0	0	16	10	1	0	11	27	1
0400	0500	27	2	2	31	21	4	1	26	57	9
0500	0600	85	13	2	100	158	23	1	182	282	39
0600	0700	350	37	4	391	629	65	4	698	1089	110
0700	0800	527	53	6	586	946	51	9	1006	1592	119
0800	0900	630	67	3	700	888	84	2	974	1674	156
0900	1000	505	67	3	575	686	67	6	759	1334	143
1000	1100	447	55	7	509	478	71	15	564	1073	148
1100	1200	482	41	3	526	516	59	3	578	1104	106
1200	1300	602	56	3	661	589	47	5	641	1302	111
1300	1400	547	54	3	604	554	59	8	621	1225	124
1400	1500	567	75	9	651	533	55	7	595	1246	146
1500	1600	835	64	6	905	642	46	8	696	1601	124
1600	1700	990	41	3	1034	757	60	5	822	1856	109
1700	1800	1013	32	0	1045	775	23	3	801	1846	58
1800	1900	619	13	1	633	641	11	1	653	1286	26
1900	2000	396	5	3	404	354	8	2	364	768	18
2000	2100	360	3	2	365	247	4	0	251	616	9
2100	2200	314	4	1	319	186	3	1	190	509	9
2200	2300	359	3	0	362	181	5	0	186	548	8
2300	2400	97	0	0	97	67	1	0	68	165	1
AM total		3156	339	32	3527	4375	429	41	4845	8372	841
PM total		6699	350	31	7080	5526	322	40	5888	12968	743
24Hr Total		9855	689	63	<b>10607</b>	9901	751	81	<b>10733</b>	<b>21340</b>	<b>1584</b>
% of Total		92.9	6.5	0.6		92.2	7.0	0.8			<b>7.4</b>

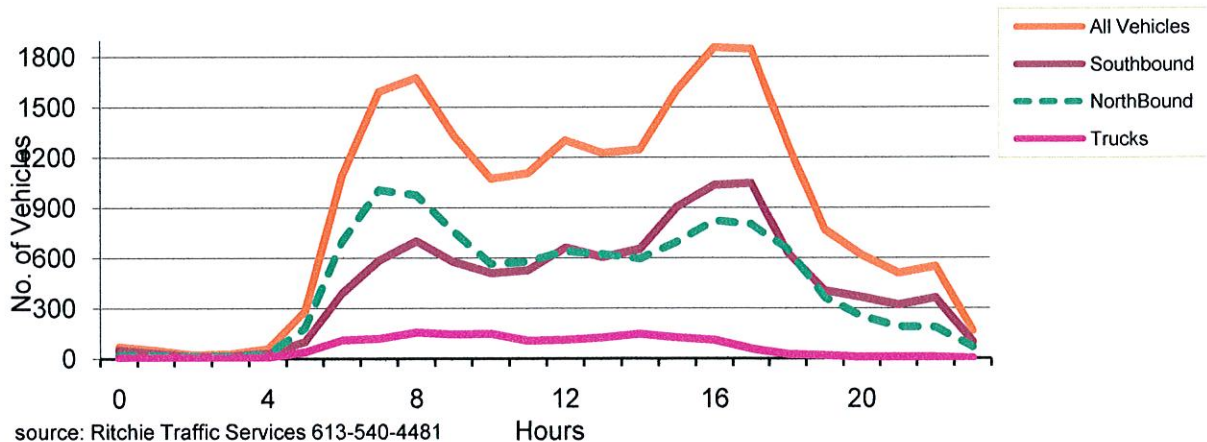

**Carp Road, south of Hwy 417 EB on-ramp  
Wednesday, April 6, 2011**

\*\*\* = partial day count

Direction		Southbound				NorthBound				SB/NB	SB/NB
Classification Categories		1-3 cars	4-7 short trucks	8-14 long trucks	SB Vehs Total	1-3 cars	4-7 short trucks	8-14 long trucks	NB Vehs Total	All Vehs Total	All Trucks Total
Start	End										
0	0100	58	1	0	59	24	0	0	24	83	1
0100	0200	25	1	1	27	14	1	0	15	42	3
0200	0300	20	0	0	20	8	1	0	9	29	1
0300	0400	13	3	0	16	9	2	0	11	27	5
0400	0500	20	3	2	25	32	3	0	35	60	8
0500	0600	105	7	0	112	155	16	0	171	283	23
0600	0700	337	44	3	384	612	53	2	667	1051	102
0700	0800	550	48	5	603	955	62	6	1023	1626	121
0800	0900	636	45	7	688	862	58	7	927	1615	117
0900	1000	464	67	4	535	653	64	4	721	1256	139
1000	1100	430	62	7	499	504	68	9	581	1080	146
1100	1200	426	37	3	466	480	59	12	551	1017	111
1200	1300	0	0	0	0	0	0	0	0	0	0
1300	1400	0	0	0	0	0	0	0	0	0	0
1400	1500	0	0	0	0	0	0	0	0	0	0
1500	1600	0	0	0	0	0	0	0	0	0	0
1600	1700	0	0	0	0	0	0	0	0	0	0
1700	1800	0	0	0	0	0	0	0	0	0	0
1800	1900	0	0	0	0	0	0	0	0	0	0
1900	2000	0	0	0	0	0	0	0	0	0	0
2000	2100	0	0	0	0	0	0	0	0	0	0
2100	2200	0	0	0	0	0	0	0	0	0	0
2200	2300	0	0	0	0	0	0	0	0	0	0
2300	2400	0	0	0	0	0	0	0	0	0	0
AM total		3084	318	32	3434	4308	387	40	4735	8169	777
PM total		0	0	0	0	0	0	0	0	0	0
*** 24Hr Total		3084	318	32	<b>3434</b>	4308	387	40	<b>4735</b>	<b>8169</b>	<b>777</b>
% of Total		89.8	9.3	0.9		91.0	8.2	0.8			<b>9.5</b>

source: Ritchie Traffic Services 613-540-4481

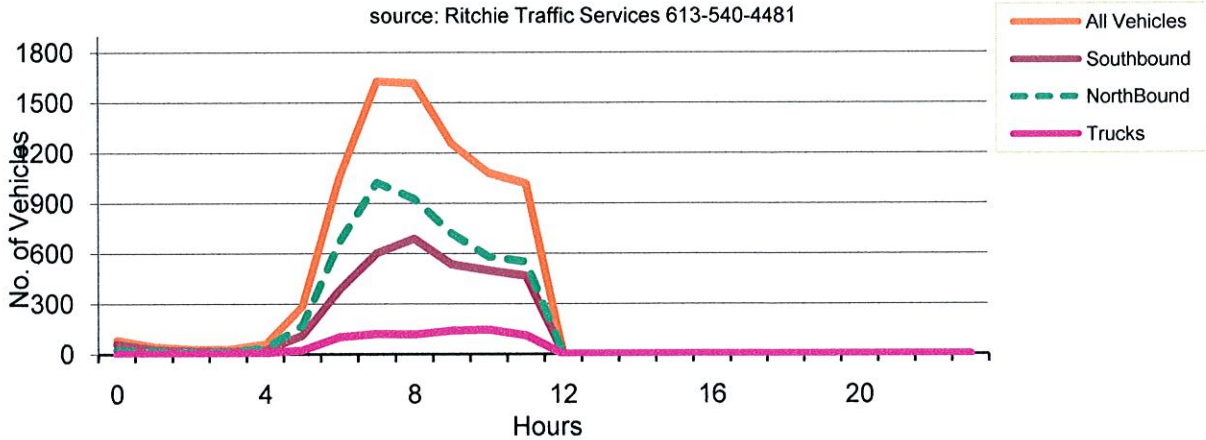

**Carp Road, north of Hwy 417 WB off-ramp  
Monday, April 4, 2011**

\*\*\* = partial day count

Direction		Southbound				NorthBound				SB/NB	SB/NB
Classification		1-3	4-7	8-14	SB	1-3	4-7	8-14	NB	All	All
Categories		cars	short trucks	long trucks	Vehs Total	cars	short trucks	long trucks	Vehs Total	Vehs Total	Trucks Total
Start	End										
0	0100	0	0	0	0	0	0	0	0	0	0
0100	0200	0	0	0	0	0	0	0	0	0	0
0200	0300	0	0	0	0	0	0	0	0	0	0
0300	0400	0	0	0	0	0	0	0	0	0	0
0400	0500	0	0	0	0	0	0	0	0	0	0
0500	0600	0	0	0	0	0	0	0	0	0	0
0600	0700	0	0	0	0	0	0	0	0	0	0
0700	0800	0	0	0	0	0	0	0	0	0	0
0800	0900	0	0	0	0	0	0	0	0	0	0
0900	1000	0	0	0	0	0	0	0	0	0	0
1000	1100	0	0	0	0	0	0	0	0	0	0
1100	1200	0	0	0	0	0	0	0	0	0	0
1200	1300	344	67	11	422	317	48	8	373	795	134
1300	1400	294	49	3	346	324	44	8	376	722	104
1400	1500	284	49	7	340	330	49	7	386	726	112
1500	1600	410	34	2	446	424	52	9	485	931	97
1600	1700	525	35	1	561	431	54	3	488	1049	93
1700	1800	375	26	3	404	404	24	0	428	832	53
1800	1900	210	14	3	227	221	11	0	232	459	28
1900	2000	144	8	3	155	175	6	0	181	336	17
2000	2100	74	5	0	79	129	4	0	133	212	9
2100	2200	81	9	0	90	114	1	0	115	205	10
2200	2300	47	3	0	50	63	1	0	64	114	4
2300	2400	23	3	1	27	39	0	2	41	68	6
AM total		0	0	0	0	0	0	0	0	0	0
PM total		2811	302	34	3147	2971	294	37	3302	6449	667
*** 24Hr Total		2811	302	34	<b>3147</b>	2971	294	37	<b>3302</b>	<b>6449</b>	<b>667</b>
% of Total		89.3	9.6	1.1		90.0	8.9	1.1			<b>10.3</b>

source: Ritchie Traffic Services 613-540-4481

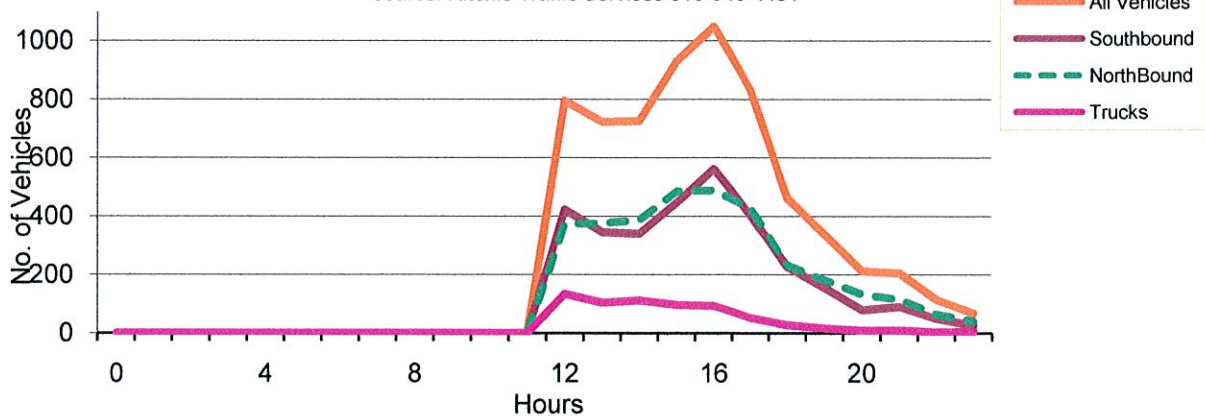

**Carp Road, north of Hwy 417 WB off-ramp  
Tuesday, April 5, 2011**

Direction		Southbound				NorthBound				SB/NB	SB/NB
Classification Categories		1-3 cars	4-7 short trucks	8-14 long trucks	SB Vehs Total	1-3 cars	4-7 short trucks	8-14 long trucks	NB Vehs Total	All Vehs Total	All Trucks Total
Start	End										
0	0100	14	1	0	15	17	2	0	19	34	3
0100	0200	9	1	0	10	11	0	0	11	21	1
0200	0300	7	0	0	7	4	1	1	6	13	2
0300	0400	8	0	0	8	14	1	1	16	24	2
0400	0500	9	1	5	15	15	2	1	18	33	9
0500	0600	67	15	2	84	88	10	3	101	185	30
0600	0700	281	63	3	347	311	34	5	350	697	105
0700	0800	426	71	10	507	438	60	7	505	1012	148
0800	0900	363	80	8	451	351	68	4	423	874	160
0900	1000	336	107	6	449	240	78	5	323	772	196
1000	1100	259	78	12	349	279	50	10	339	688	150
1100	1200	285	71	7	363	274	63	6	343	706	147
1200	1300	338	69	9	416	322	65	8	395	811	151
1300	1400	298	91	2	391	350	56	14	420	811	163
1400	1500	309	84	10	403	354	54	11	419	822	159
1500	1600	390	64	8	462	447	60	7	514	976	139
1600	1700	489	81	5	575	442	47	3	492	1067	136
1700	1800	397	53	0	450	403	24	1	428	878	78
1800	1900	214	31	2	247	285	7	0	292	539	40
1900	2000	143	19	2	164	185	9	2	196	360	32
2000	2100	121	4	1	126	170	9	0	179	305	14
2100	2200	70	6	0	76	125	2	0	127	203	8
2200	2300	67	5	0	72	92	6	0	98	170	11
2300	2400	37	2	0	39	36	2	0	38	77	4
AM total		2064	488	53	2605	2042	369	43	2454	5059	953
PM total		2873	509	39	3421	3211	341	46	3598	7019	935
24Hr Total		4937	997	92	<b>6026</b>	5253	710	89	<b>6052</b>	<b>12078</b>	<b>1888</b>
% of Total		81.9	16.5	1.5		86.8	11.7	1.5			<b>15.6</b>

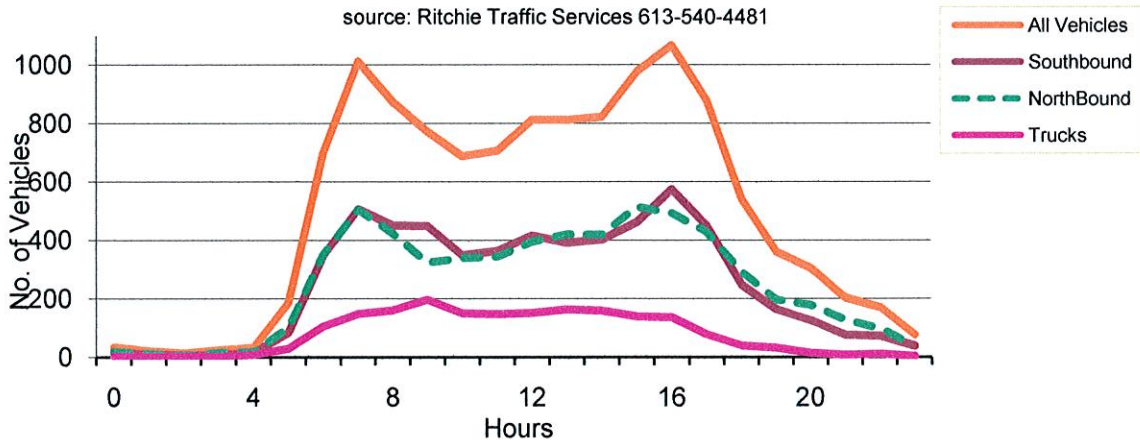

**Richardson Road, west of Carp Road  
Monday, April 4, 2011**

\*\*\* = partial day count

Direction		Westbound				EastBound				WB/EB	WB/EB
Classification #		1-3	4-7	8-14	SB	1-3	4-7	8-14	NB	All	All
Categories		cars	short trucks	long trucks	Vehs Total	cars	short trucks	long trucks	Vehs Total	Vehs Total	Trucks Total
Start	End										
0	0100	0	0	0	0	0	0	0	0	0	0
0100	0200	0	0	0	0	0	0	0	0	0	0
0200	0300	0	0	0	0	0	0	0	0	0	0
0300	0400	0	0	0	0	0	0	0	0	0	0
0400	0500	0	0	0	0	0	0	0	0	0	0
0500	0600	0	0	0	0	0	0	0	0	0	0
0600	0700	0	0	0	0	0	0	0	0	0	0
0700	0800	0	0	0	0	0	0	0	0	0	0
0800	0900	0	0	0	0	0	0	0	0	0	0
0900	1000	0	0	0	0	0	0	0	0	0	0
1000	1100	0	0	0	0	0	0	0	0	0	0
1100	1200	0	0	0	0	0	0	0	0	0	0
1200	1300	108	13	2	123	124	22	0	146	269	37
1300	1400	116	18	0	134	92	30	0	122	256	48
1400	1500	128	21	0	149	77	34	0	111	260	55
1500	1600	169	30	1	200	97	18	0	115	315	49
1600	1700	241	51	0	292	153	16	0	169	461	67
1700	1800	246	9	0	255	103	15	0	118	373	24
1800	1900	151	7	0	158	93	11	0	104	262	18
1900	2000	100	6	0	106	70	4	1	75	181	11
2000	2100	84	5	0	89	34	1	0	35	124	6
2100	2200	62	0	0	62	20	5	0	25	87	5
2200	2300	33	1	0	34	15	2	0	17	51	3
2300	2400	28	1	0	29	6	2	0	8	37	3
AM total		0	0	0	0	0	0	0	0	0	0
PM total		1466	162	3	1631	884	160	1	1045	2676	326
*** 24Hr Total		1466	162	3	1631	884	160	1	1045	2676	326
% of Total		89.9	9.9	0.2		84.6	15.3	0.1			12.2

source: Ritchie Traffic Services 613-540-4481

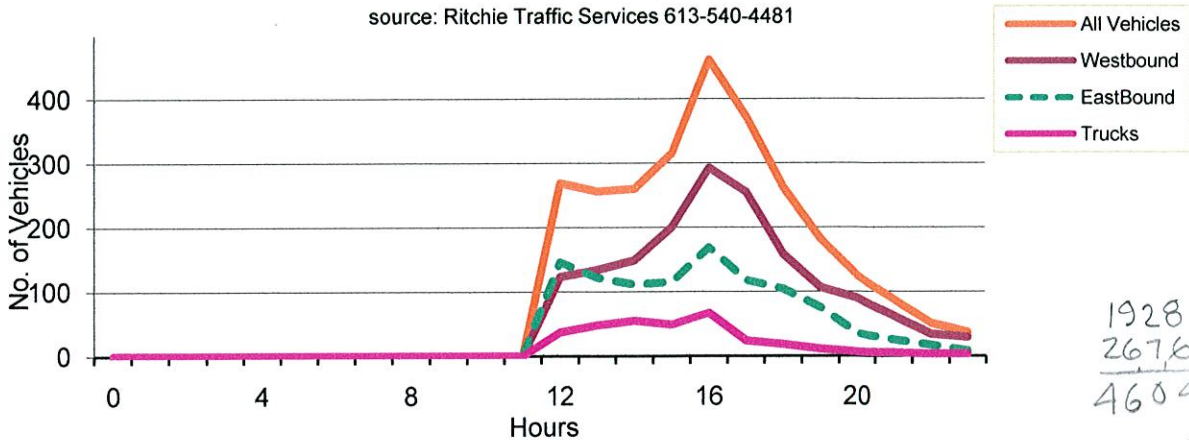

1928  
 2676  
 4604  
 4739  
 394  
 326  
 720  
 15.2%  
 trucks

**Richardson Road, west of Carp Road  
Tuesday, April 5, 2011**

Direction		Westbound				EastBound				WB/EB	WB/EB
Classification #		1-3	4-7	8-14	<sup>W</sup> SB Vehs Total	1-3	4-7	8-14	<sup>E</sup> NB Vehs Total	All Vehs Total	All Trucks Total
Categories		cars	short trucks	long trucks		cars	short trucks	long trucks			
Start	End										
0	0100	12	0	0	12	3	3	0	6	18	3
0100	0200	4	0	0	4	1	0	0	1	5	0
0200	0300	3	1	0	4	2	0	0	2	6	1
0300	0400	3	0	0	3	4	1	0	5	8	1
0400	0500	2	0	1	3	4	2	0	6	9	3
0500	0600	34	4	0	38	42	7	0	49	87	11
0600	0700	79	11	1	91	147	55	0	202	293	67
0700	0800	87	11	0	98	266	65	0	331	429	76
0800	0900	91	26	1	118	198	19	0	217	335	46
0900	1000	75	25	0	100	147	23	1	171	271	49
1000	1100	71	9	1	81	108	24	0	132	213	34
1100	1200	96	14	0	110	114	23	0	137	247	37
1200	1300	106	20	1	127	101	20	0	121	248	41
1300	1400	122	21	1	144	78	38	0	116	260	60
1400	1500	121	19	1	141	84	28	0	112	253	48
1500	1600	194	31	2	227	106	21	0	127	354	54
1600	1700	249	46	1	296	146	22	1	169	465	70
1700	1800	258	10	0	268	116	14	0	130	398	24
1800	1900	157	6	0	163	98	12	0	110	273	18
1900	2000	102	7	0	109	58	9	0	67	176	16
2000	2100	81	6	0	87	60	2	0	62	149	8
2100	2200	74	3	0	77	26	1	0	27	104	4
2200	2300	65	5	0	70	26	1	0	27	97	6
2300	2400	31	2	0	33	7	1	0	8	41	3
AM total		557	101	4	662	1036	222	1	1259	1921	328
PM total		1560	176	6	1742	906	169	1	1076	2818	352
24Hr Total		2117	277	10	<b>2404</b>	1942	391	2	<b>2335</b>	<b>4739</b>	<b>680</b>
% of Total		88.1	11.5	0.4		83.2	16.7	0.1			<b>14.3</b>

source: Ritchie Traffic Services 613-540-4481

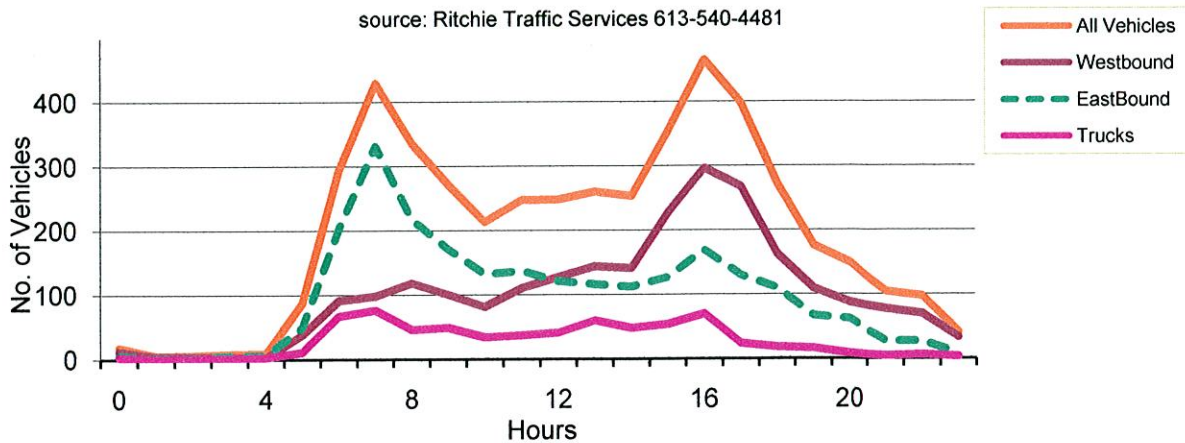



**Richardson Road, west of Carp Road  
Wednesday, April 6, 2011**

\*\*\* = partial day count

Direction		Westbound				EastBound				WB/EB	WB/EB
Classification #		1-3	4-7	8-14	SB	1-3	4-7	8-14	NB	All	All
Categories		cars	short	long	Vehs	cars	short	long	Vehs	Vehs	Trucks
			trucks	trucks	Total		trucks	trucks	Total	Total	Total
Start	End										
0	0100	10	2	0	12	4	1	0	5	17	3
0100	0200	9	2	0	11	5	2	0	7	18	4
0200	0300	2	0	0	2	1	1	1	3	5	2
0300	0400	1	0	0	1	3	2	0	5	6	2
0400	0500	3	3	2	8	4	3	1	8	16	9
0500	0600	33	7	0	40	36	9	0	45	85	16
0600	0700	86	9	0	95	156	47	1	204	299	57
0700	0800	77	14	1	92	288	63	0	351	443	78
0800	0900	91	34	1	126	195	27	0	222	348	62
0900	1000	69	30	1	100	147	31	0	178	278	62
1000	1100	75	19	3	97	85	20	0	105	202	42
1100	1200	66	19	0	85	88	38	0	126	211	57
1200	1300	0	0	0	0	0	0	0	0	0	0
1300	1400	0	0	0	0	0	0	0	0	0	0
1400	1500	0	0	0	0	0	0	0	0	0	0
1500	1600	0	0	0	0	0	0	0	0	0	0
1600	1700	0	0	0	0	0	0	0	0	0	0
1700	1800	0	0	0	0	0	0	0	0	0	0
1800	1900	0	0	0	0	0	0	0	0	0	0
1900	2000	0	0	0	0	0	0	0	0	0	0
2000	2100	0	0	0	0	0	0	0	0	0	0
2100	2200	0	0	0	0	0	0	0	0	0	0
2200	2300	0	0	0	0	0	0	0	0	0	0
2300	2400	0	0	0	0	0	0	0	0	0	0
AM total		522	139	8	669	1012	244	3	1259	1928	394
PM total		0	0	0	0	0	0	0	0	0	0
*** 24Hr Total		522	139	8	669	1012	244	3	1259	1928	394
% of Total		78.0	20.8	1.2		80.4	19.4	0.2			20.4

source: Ritchie Traffic Services 613-540-4481

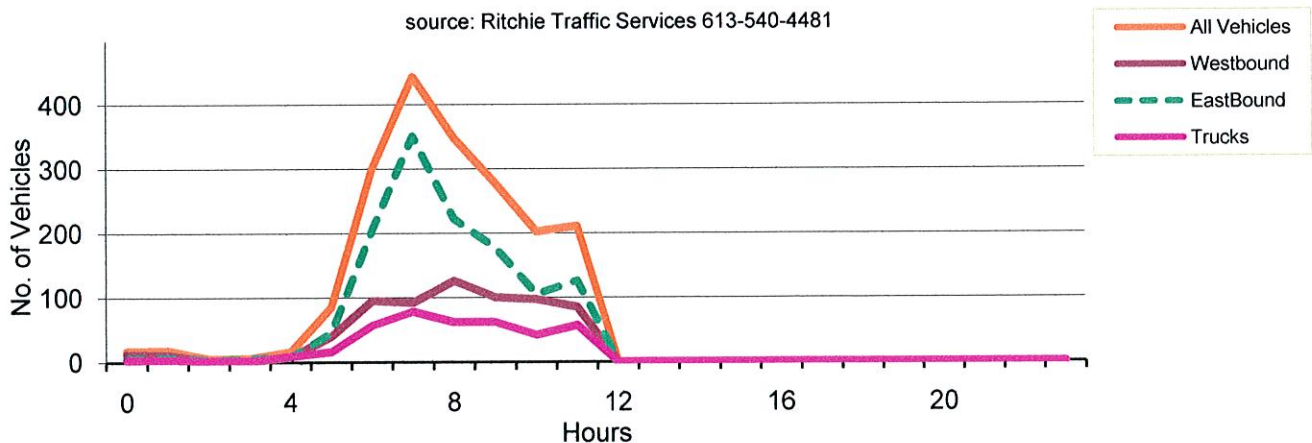

Peak Hour Factors (PHF) - May-June, 2011

Carp Road, north of Hwy 417 WB to NB Off-ramp

				SB+NB	SB+NB	SB+NB
				Total	PHF	% Trk
Monday, May 30, 2011	AM	7:15-8:15	All Veh.	572	0.86	35.8%
			Short Trk	176		30.8%
			Long Trk	29		5.1%
	PM	3:45-4:45	All Veh.	572	0.87	29.4%
			Short Trk	158		27.6%
			Long Trk	10		1.7%
Tuesday, May 31, 2011	AM	7:30-8:30	All Veh.	549	0.98	33.3%
			Short Trk	150		27.3%
			Long Trk	33		6.0%
	PM	3:45-4:45	All Veh.	587	0.94	33.2%
			Short Trk	175		29.8%
			Long Trk	20		3.4%
Wednesday, June 1, 2011	AM	7:15-8:15	All Veh.	539	0.84	35.1%
			Short Trk	166		30.8%
			Long Trk	23		4.3%
	PM	3:45-4:45	All Veh.	595	0.86	31.8%
			Short Trk	170		28.6%
			Long Trk	19		3.2%
Thursday, June 2, 2011	AM	7:00-8:00	All Veh.	530	0.84	32.6%
			Short Trk	162		30.6%
			Long Trk	11		2.1%
	PM	3:45-4:45	All Veh.	602	0.97	30.1%
			Short Trk	168		27.9%
			Long Trk	13		2.2%
Friday, June 3, 2011	AM	7:45-8:45	All Veh.	537	0.84	38.7%
			Short Trk	180		33.5%
			Long Trk	28		5.2%
	PM	3:45-4:45	All Veh.	589	0.92	29.9%
			Short Trk	157		26.7%
			Long Trk	19		3.2%

**Carp Road, north of Hwy 417 WB to NB Off-ramp  
Monday, May 30, 2011**

Direction		Southbound				NorthBound				SB/NB	SB/NB
Classification Categories		1-3 cars	4-7 short trucks	8-14 long trucks	SB Vehs Total	1-3 cars	4-7 short trucks	8-14 long trucks	NB Vehs Total	All Vehs Total	All Trucks Total
Start	End										
0	0100	16	1	0	17	22	0	0	22	39	1
0100	0200	5	0	0	5	7	0	1	8	13	1
0200	0300	3	0	0	3	11	0	0	11	14	0
0300	0400	9	0	0	9	8	1	2	11	20	3
0400	0500	9	4	6	19	18	7	0	25	44	17
0500	0600	80	23	5	108	89	21	2	112	220	51
0600	0700	331	79	11	421	348	87	6	441	862	183
0700	0800	477	78	13	568	454	90	17	561	1129	198
0800	0900	450	70	12	532	372	108	11	491	1023	201
0900	1000	368	80	15	463	303	87	14	404	867	196
1000	1100	319	75	7	401	308	89	11	408	809	182
1100	1200	343	68	13	424	327	98	10	435	859	189
1200	1300	379	70	11	460	330	84	12	426	886	177
1300	1400	340	57	6	403	325	78	9	412	815	150
1400	1500	321	75	13	409	340	76	17	433	842	181
1500	1600	446	73	4	523	394	118	9	521	1044	204
1600	1700	514	50	9	573	446	89	6	541	1114	154
1700	1800	444	40	6	490	438	62	6	506	996	114
1800	1900	298	35	4	337	297	40	4	341	678	83
1900	2000	177	18	2	197	207	18	4	229	426	42
2000	2100	176	10	3	189	196	16	1	213	402	30
2100	2200	81	4	0	85	124	13	1	138	223	18
2200	2300	46	2	2	50	72	6	0	78	128	10
2300	2400	23	0	0	23	28	4	0	32	55	4
AM total		2410	478	82	2970	2267	588	74	2929	5899	1222
PM total		3245	434	60	3739	3197	604	69	3870	7609	1167
24Hr Total		5655	912	142	<b>6709</b>	5464	1192	143	<b>6799</b>	<b>13508</b>	<b>2389</b>
% of Total		84.3	13.6	2.1		80.4	17.5	2.1			<b>17.7</b>

source: Ritchie Traffic Services 613-540-4481

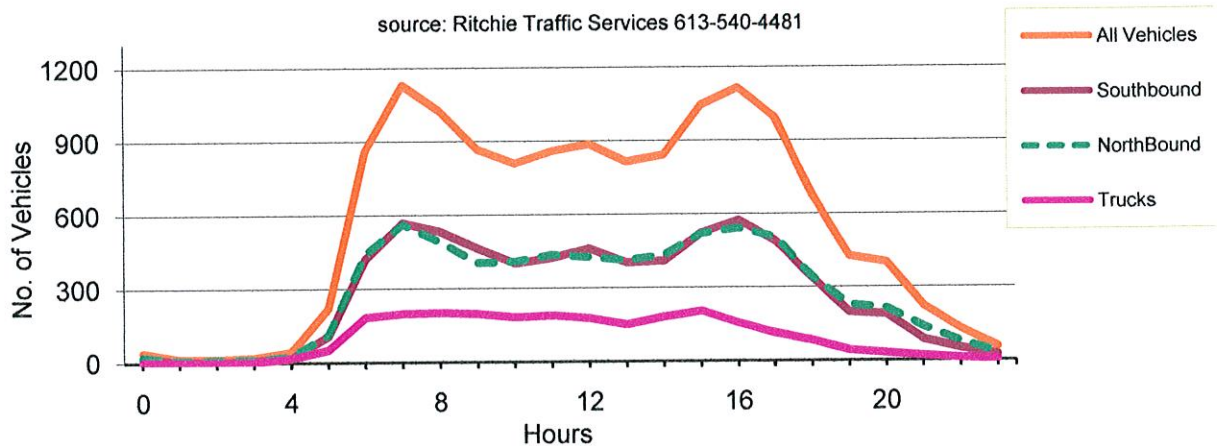

**Carp Road, north of Hwy 417 WB to NB Off-ramp  
Tuesday, May 31, 2011**

Direction		Southbound				NorthBound				SB/NB	SB/NB
Classification Categories		1-3 cars	4-7 short trucks	8-14 long trucks	SB Vehs Total	1-3 cars	4-7 short trucks	8-14 long trucks	NB Vehs Total	All Vehs Total	All Trucks Total
Start	End										
0	0100	11	1	0	12	17	0	0	17	29	1
0100	0200	6	0	0	6	7	2	0	9	15	2
0200	0300	6	0	0	6	10	2	3	15	21	5
0300	0400	7	2	2	11	10	2	1	13	24	7
0400	0500	12	3	3	18	12	4	1	17	35	11
0500	0600	93	18	2	113	86	20	3	109	222	43
0600	0700	332	71	14	417	382	71	8	461	878	164
0700	0800	503	74	8	585	417	79	11	507	1092	172
0800	0900	442	63	21	526	392	95	18	505	1031	197
0900	1000	392	80	9	481	312	95	12	419	900	196
1000	1100	351	77	14	442	315	90	15	420	862	196
1100	1200	366	78	12	456	313	89	11	413	869	190
1200	1300	383	70	8	461	380	92	13	485	946	183
1300	1400	355	114	10	479	397	126	14	537	1016	264
1400	1500	370	103	15	488	374	103	13	490	978	234
1500	1600	448	69	10	527	432	114	8	554	1081	201
1600	1700	533	78	5	616	470	91	11	572	1188	185
1700	1800	466	54	9	529	449	51	7	507	1036	121
1800	1900	330	19	1	350	301	23	1	325	675	44
1900	2000	226	14	3	243	266	25	5	296	539	47
2000	2100	184	12	2	198	190	12	1	203	401	27
2100	2200	134	4	0	138	145	10	0	155	293	14
2200	2300	64	6	0	70	79	4	0	83	153	10
2300	2400	29	3	0	32	46	4	0	50	82	7
AM total		2521	467	85	3073	2273	549	83	2905	5978	1184
PM total		3522	546	63	4131	3529	655	73	4257	8388	1337
24Hr Total		6043	1013	148	<b>7204</b>	5802	1204	156	<b>7162</b>	<b>14366</b>	<b>2521</b>
% of Total		83.9	14.1	2.1		81.0	16.8	2.2			<b>17.5</b>

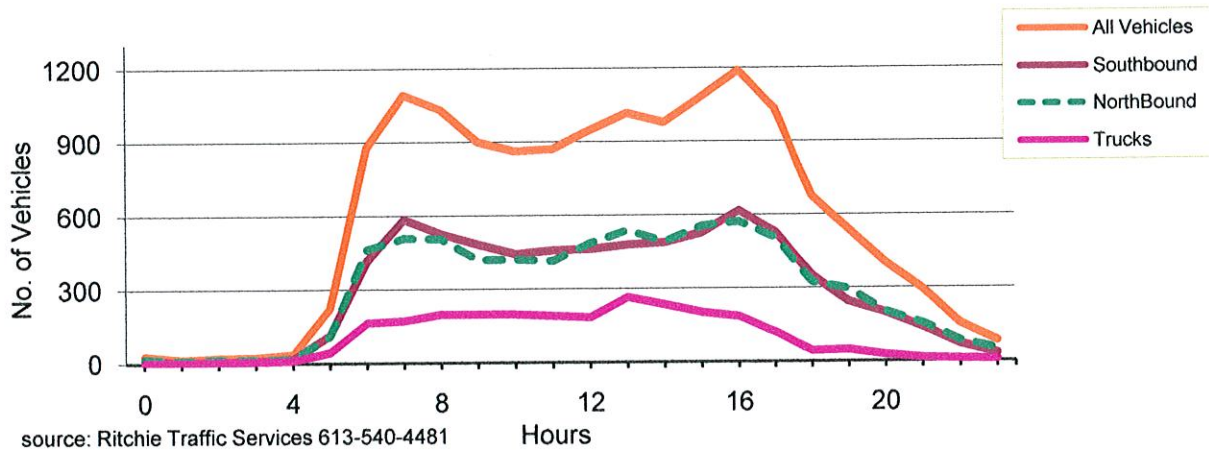

**Carp Road, north of Hwy 417 WB to NB Off-ramp  
Wednesday, June 1, 2011**

Direction		Southbound				NorthBound				SB/NB	SB/NB
Classification Categories		1-3 cars	4-7 short trucks	8-14 long trucks	SB Vehs Total	1-3 cars	4-7 short trucks	8-14 long trucks	NB Vehs Total	All Vehs Total	All Trucks Total
Start	End										
0	0100	11	0	0	11	22	1	0	23	34	1
0100	0200	11	0	0	11	8	1	1	10	21	2
0200	0300	1	1	0	2	13	3	1	17	19	5
0300	0400	10	0	0	10	5	3	0	8	18	3
0400	0500	8	4	1	13	22	5	5	32	45	15
0500	0600	96	16	6	118	79	29	2	110	228	53
0600	0700	321	79	11	411	336	77	11	424	835	178
0700	0800	472	82	10	564	422	93	9	524	1088	194
0800	0900	469	62	8	539	391	82	13	486	1025	165
0900	1000	369	76	11	456	338	99	14	451	907	200
1000	1100	377	72	18	467	320	99	15	434	901	204
1100	1200	377	90	12	479	343	92	10	445	924	204
1200	1300	402	68	13	483	403	90	9	502	985	180
1300	1400	360	93	12	465	350	97	17	464	929	219
1400	1500	371	98	10	479	377	85	7	469	948	200
1500	1600	469	82	9	560	419	118	10	547	1107	219
1600	1700	520	55	12	587	476	99	7	582	1169	173
1700	1800	443	46	1	490	456	47	6	509	999	100
1800	1900	288	15	4	307	323	30	1	354	661	50
1900	2000	183	12	1	196	209	19	0	228	424	32
2000	2100	179	12	1	192	216	13	3	232	424	29
2100	2200	107	9	0	116	147	8	0	155	271	17
2200	2300	74	3	0	77	84	11	0	95	172	14
2300	2400	26	4	0	30	41	5	0	46	76	9
AM total		2522	482	77	3081	2299	584	81	2964	6045	1224
PM total		3422	497	63	3982	3501	622	60	4183	8165	1242
24Hr Total		5944	979	140	<b>7063</b>	5800	1206	141	<b>7147</b>	<b>14210</b>	<b>2466</b>
% of Total		84.2	13.9	2.0		81.2	16.9	2.0			<b>17.4</b>

source: Ritchie Traffic Services 613-540-4481

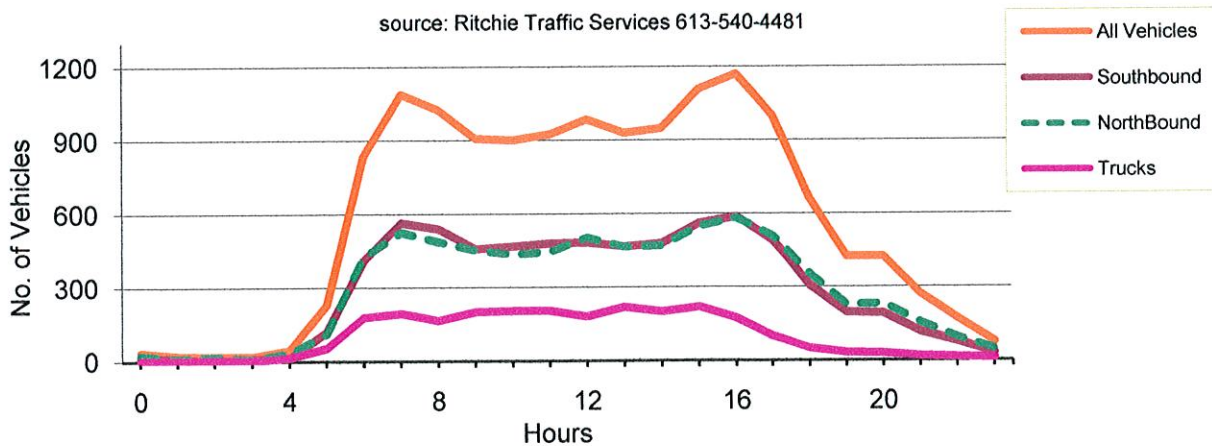

**Carp Road, north of Hwy 417 WB to NB Off-ramp  
Thursday, June 2, 2011**

Direction		Southbound				NorthBound				SB/NB	SB/NB
Classification Categories		1-3 cars	4-7 short trucks	8-14 long trucks	SB Vehs Total	1-3 cars	4-7 short trucks	8-14 long trucks	NB Vehs Total	All Vehs Total	All Trucks Total
Start	End										
0	0100	13	2	0	15	18	2	0	20	35	4
0100	0200	8	2	0	10	10	1	0	11	21	3
0200	0300	4	0	1	5	3	0	0	3	8	1
0300	0400	9	1	0	10	8	5	2	15	25	8
0400	0500	15	2	3	20	19	5	3	27	47	13
0500	0600	79	14	8	101	80	25	2	107	208	49
0600	0700	328	92	11	431	343	67	12	422	853	182
0700	0800	473	89	5	567	451	72	6	529	1096	172
0800	0900	446	71	5	522	383	69	9	461	983	154
0900	1000	381	61	14	456	322	83	15	420	876	173
1000	1100	335	64	11	410	298	68	20	386	796	163
1100	1200	294	70	12	376	309	75	8	392	768	165
1200	1300	415	78	11	504	339	83	15	437	941	187
1300	1400	338	83	11	432	350	103	13	466	898	210
1400	1500	337	94	16	447	347	98	10	455	902	218
1500	1600	419	69	8	496	452	100	8	560	1056	185
1600	1700	533	69	3	605	476	105	10	591	1196	187
1700	1800	503	47	4	554	421	70	6	497	1051	127
1800	1900	332	30	4	366	381	36	6	423	789	76
1900	2000	192	12	0	204	248	17	2	267	471	31
2000	2100	161	11	0	172	216	11	3	230	402	25
2100	2200	144	7	2	153	156	8	2	166	319	19
2200	2300	63	0	0	63	90	4	1	95	158	5
2300	2400	39	0	0	39	42	7	0	49	88	7
AM total		2385	468	70	2923	2244	472	77	2793	5716	1087
PM total		3476	500	59	4035	3518	642	76	4236	8271	1277
24Hr Total		5861	968	129	<b>6958</b>	5762	1114	153	<b>7029</b>	<b>13987</b>	<b>2364</b>
% of Total		84.2	13.9	1.9		82.0	15.8	2.2			<b>16.9</b>

source: Ritchie Traffic Services 613-540-4481

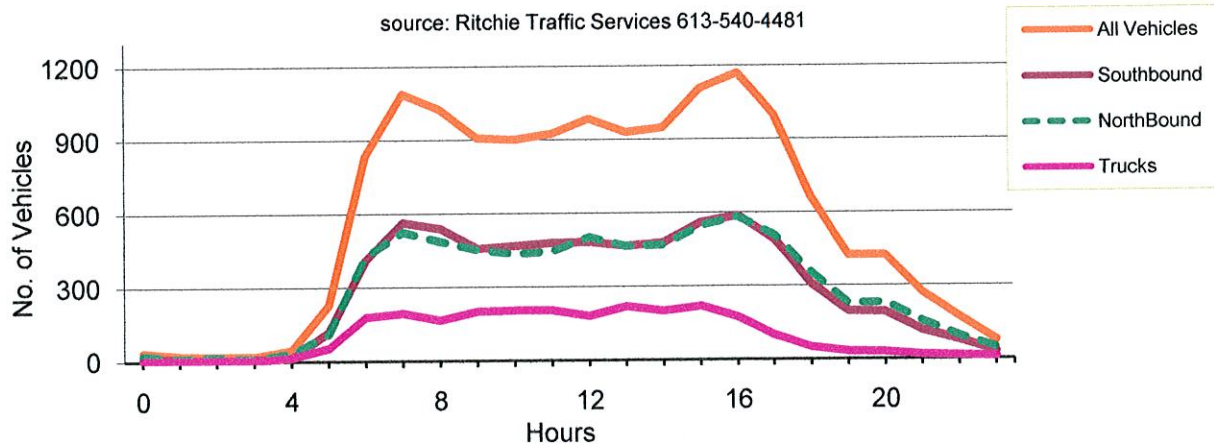

**Carp Road, north of Hwy 417 WB to NB Off-ramp  
Friday, June 3, 2011**

Direction		Southbound				NorthBound				SB/NB	SB/NB
Classification Categories		1-3 cars	4-7 short trucks	8-14 long trucks	SB Vehs Total	1-3 cars	4-7 short trucks	8-14 long trucks	NB Vehs Total	All Vehs Total	All Trucks Total
Start	End										
0	0100	15	0	0	15	30	4	0	34	49	4
0100	0200	11	0	0	11	12	0	0	12	23	0
0200	0300	6	0	0	6	13	0	0	13	19	0
0300	0400	12	2	1	15	10	11	2	23	38	16
0400	0500	10	2	5	17	19	6	1	26	43	14
0500	0600	87	20	4	111	83	14	7	104	215	45
0600	0700	287	64	8	359	302	90	9	401	760	171
0700	0800	487	71	11	569	412	83	11	506	1075	176
0800	0900	411	65	12	488	398	73	13	484	972	163
0900	1000	366	83	12	461	316	88	15	419	880	198
1000	1100	374	79	13	466	316	85	19	420	886	196
1100	1200	356	86	12	454	357	86	19	462	916	203
1200	1300	439	83	14	536	415	89	8	512	1048	194
1300	1400	377	73	15	465	420	94	20	534	999	202
1400	1500	401	61	17	479	424	103	10	537	1016	191
1500	1600	436	73	11	520	425	89	9	523	1043	182
1600	1700	476	48	5	529	485	71	10	566	1095	134
1700	1800	455	22	7	484	396	45	6	447	931	80
1800	1900	297	15	3	315	312	25	6	343	658	49
1900	2000	201	11	1	213	193	13	0	206	419	25
2000	2100	168	5	1	174	169	13	1	183	357	20
2100	2200	131	5	0	136	145	13	0	158	294	18
2200	2300	79	6	0	85	95	6	0	101	186	12
2300	2400	47	0	0	47	59	7	0	66	113	7
AM total		2422	472	78	2972	2268	540	96	2904	5876	1186
PM total		3507	402	74	3983	3538	568	70	4176	8159	1114
24Hr Total		5929	874	152	6955	5806	1108	166	7080	14035	2300
% of Total		85.2	12.6	2.2		82.0	15.6	2.3			16.4

source: Ritchie Traffic Services 613-540-4481

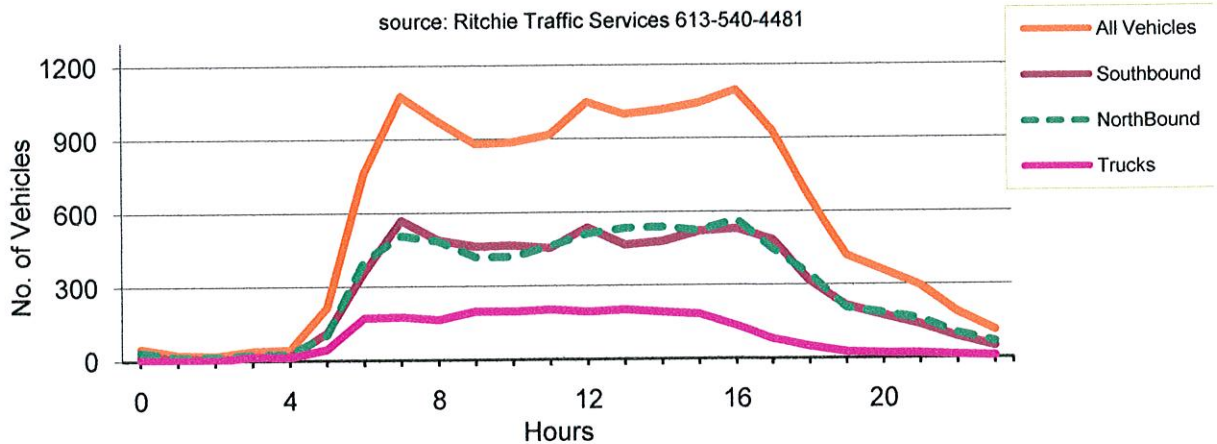

Peak Hour Factors (PHF) - May-June, 2011

Carp Road, south of Hwy 417 NB to EB On-ramp

				SB+NB Total	SB+NB PHF	SB+NB % Trk
Monday, May 30, 2011	AM	7:45-8:45	All Veh.	1867	0.88	10.1%
			Short Trk	174		9.3%
			Long Trk	14		0.7%
	PM	4:30-5:30	All Veh.	2078	0.94	7.6%
			Short Trk	148		7.1%
			Long Trk	9		0.4%
Tuesday, May 31, 2011	AM	7:30-8:30	All Veh.	1903	0.93	9.6%
			Short Trk	157		8.3%
			Long Trk	25		1.3%
	PM	4:30-5:30	All Veh.	2067	0.94	6.5%
			Short Trk	124		6.0%
			Long Trk	10		0.5%
Wednesday, June 1, 2011	AM	7:30-8:30	All Veh.	1917	0.96	9.7%
			Short Trk	173		9.0%
			Long Trk	13		0.7%
	PM	4:45-5:45	All Veh.	2001	0.98	7.8%
			Short Trk	152		7.6%
			Long Trk	5		0.2%
Thursday, June 2, 2011	AM	7:30-8:30	All Veh.	1859	0.88	10.1%
			Short Trk	179		9.6%
			Long Trk	9		0.5%
	PM	4:30-5:30	All Veh.	2079	0.93	7.3%
			Short Trk	142		6.8%
			Long Trk	10		0.5%
Friday, June 3, 2011	AM	7:45-8:45	All Veh.	1755	0.91	9.5%
			Short Trk	151		8.6%
			Long Trk	16		0.9%
	PM	3:30-4:30	All Veh.	1946	0.93	8.9%
			Short Trk	160		8.2%
			Long Trk	14		0.7%



**Carp Road, south of Hwy 417 NB to EB On-ramp  
Monday, May 30, 2011**

Direction		Southbound				NorthBound				SB/NB	SB/NB
Classification Categories		1-3 cars	4-7 short trucks	8-14 long trucks	SB Vehs Total	1-3 cars	4-7 short trucks	8-14 long trucks	NB Vehs Total	All Vehs Total	All Trucks Total
Start	End										
0	0100	48	2	0	50	14	1	0	15	65	3
0100	0200	20	1	0	21	9	0	0	9	30	1
0200	0300	7	0	1	8	9	1	0	10	18	2
0300	0400	8	1	0	9	11	1	1	13	22	3
0400	0500	30	3	2	35	30	6	0	36	71	11
0500	0600	115	27	1	143	162	31	2	195	338	61
0600	0700	449	82	8	539	682	95	6	783	1322	191
0700	0800	568	96	3	667	940	82	2	1024	1691	183
0800	0900	677	70	9	756	959	82	6	1047	1803	167
0900	1000	494	88	3	585	664	77	6	747	1332	174
1000	1100	439	92	3	534	514	87	7	608	1142	189
1100	1200	473	60	5	538	499	75	10	584	1122	150
1200	1300	602	88	4	694	564	58	7	629	1323	157
1300	1400	568	71	5	644	548	75	3	626	1270	154
1400	1500	635	74	6	715	554	59	4	617	1332	143
1500	1600	791	105	7	903	630	106	9	745	1648	227
1600	1700	971	74	6	1051	771	87	6	864	1915	173
1700	1800	1029	56	4	1089	849	66	3	918	2007	129
1800	1900	662	45	3	710	553	31	3	587	1297	82
1900	2000	462	35	3	500	413	18	1	432	932	57
2000	2100	493	16	1	510	361	20	1	382	892	38
2100	2200	320	14	0	334	223	16	0	239	573	30
2200	2300	141	12	0	153	115	6	0	121	274	18
2300	2400	95	5	0	100	64	2	0	66	166	7
AM total		3328	522	35	3885	4493	538	40	5071	8956	1135
PM total		6769	595	39	7403	5645	544	37	6226	13629	1215
24Hr Total		10097	1117	74	<b>11288</b>	10138	1082	77	<b>11297</b>	<b>22585</b>	<b>2350</b>
% of Total		89.4	9.9	0.7		89.7	9.6	0.7			<b>10.4</b>

source: Ritchie Traffic Services 613-540-4481

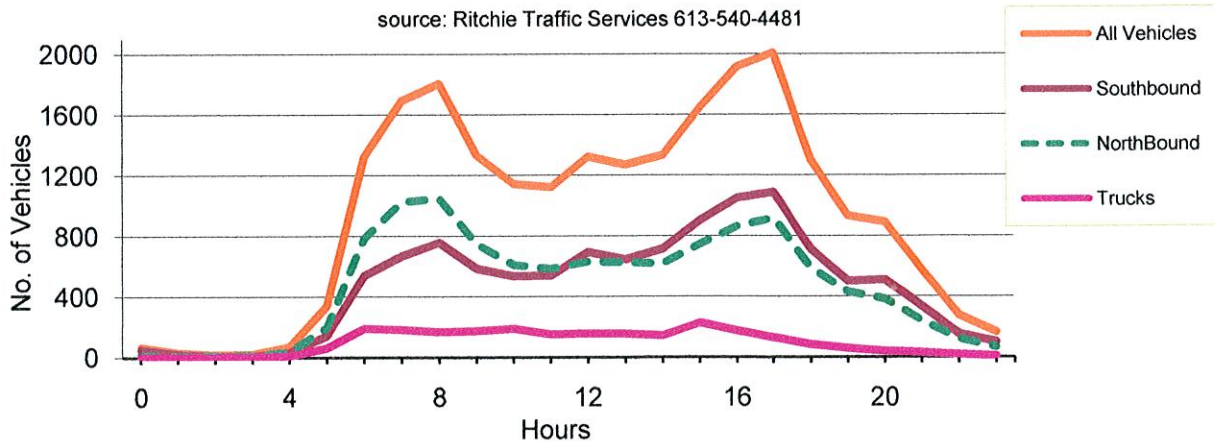

**Carp Road, south of Hwy 417 NB to EB On-ramp  
Tuesday, May 31, 2011**

Direction	Southbound				NorthBound				SB/NB	SB/NB	
	1-3 cars	4-7 short trucks	8-14 long trucks	SB Vehs Total	1-3 cars	4-7 short trucks	8-14 long trucks	NB Vehs Total	All Vehs Total	All Trucks Total	
Start	End										
0	0100	38	2	0	40	22	1	0	23	63	3
0100	0200	21	2	0	23	7	2	0	9	32	4
0200	0300	12	3	0	15	5	2	0	7	22	5
0300	0400	11	4	0	15	12	3	0	15	30	7
0400	0500	24	2	0	26	26	8	1	35	61	11
0500	0600	125	26	2	153	175	37	0	212	365	65
0600	0700	386	83	4	473	693	88	4	785	1258	179
0700	0800	605	95	8	708	983	80	9	1072	1780	192
0800	0900	649	69	10	728	920	88	13	1021	1749	180
0900	1000	527	82	5	614	658	105	7	770	1384	199
1000	1100	472	90	9	571	553	94	8	655	1226	201
1100	1200	542	95	6	643	545	84	6	635	1278	191
1200	1300	611	86	5	702	583	71	5	659	1361	167
1300	1400	564	109	9	682	593	88	10	691	1373	216
1400	1500	631	99	10	740	610	90	6	706	1446	205
1500	1600	806	76	5	887	719	76	5	800	1687	162
1600	1700	946	71	7	1024	851	79	5	935	1959	162
1700	1800	982	76	3	1061	836	53	4	893	1954	136
1800	1900	738	45	6	789	605	32	2	639	1428	85
1900	2000	456	31	2	489	477	29	1	507	996	63
2000	2100	480	14	1	495	363	16	3	382	877	34
2100	2200	357	11	0	368	235	12	0	247	615	23
2200	2300	268	9	0	277	127	5	0	132	409	14
2300	2400	133	7	1	141	96	7	0	103	244	15
AM total		3412	553	44	4009	4599	592	48	5239	9248	1237
PM total		6972	634	49	7655	6095	558	41	6694	14349	1282
24Hr Total		10384	1187	93	<b>11664</b>	10694	1150	89	<b>11933</b>	<b>23597</b>	<b>2519</b>
% of Total		89.0	10.2	0.8		89.6	9.6	0.7			<b>10.7</b>

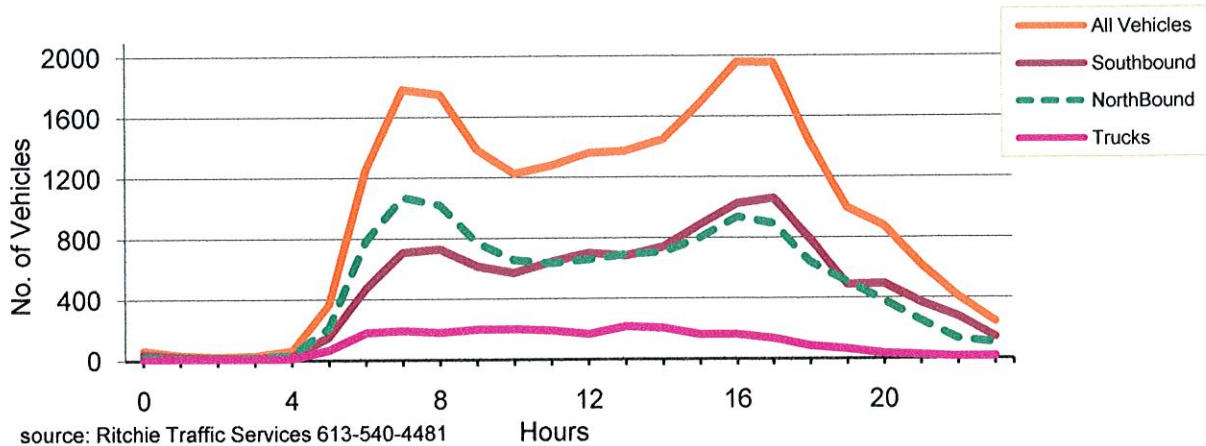

**Carp Road, south of Hwy 417 NB to EB On-ramp  
Wednesday, June 1, 2011**

Direction		Southbound				NorthBound				SB/NB	SB/NB
Classification Categories		1-3 cars	4-7 short trucks	8-14 long trucks	SB Vehs Total	1-3 cars	4-7 short trucks	8-14 long trucks	NB Vehs Total	All Vehs Total	All Trucks Total
Start	End										
0	0100	72	2	0	74	31	0	0	31	105	2
0100	0200	22	2	0	24	10	2	0	12	36	4
0200	0300	19	0	0	19	13	1	0	14	33	1
0300	0400	13	0	0	13	10	1	0	11	24	1
0400	0500	33	3	1	37	34	6	1	41	78	11
0500	0600	127	29	0	156	170	31	3	204	360	63
0600	0700	438	101	3	542	672	109	6	787	1329	219
0700	0800	551	84	3	638	1001	99	9	1109	1747	195
0800	0900	708	89	5	802	932	90	7	1029	1831	191
0900	1000	512	100	6	618	671	118	6	795	1413	230
1000	1100	465	81	4	550	543	78	10	631	1181	173
1100	1200	542	88	6	636	571	85	7	663	1299	186
1200	1300	626	74	6	706	593	99	12	704	1410	191
1300	1400	541	111	8	660	588	97	9	694	1354	225
1400	1500	597	110	8	715	577	83	5	665	1380	206
1500	1600	790	79	7	876	690	92	5	787	1663	183
1600	1700	947	68	5	1020	852	84	6	942	1962	163
1700	1800	973	75	2	1050	822	60	4	886	1936	141
1800	1900	668	46	1	715	649	44	2	695	1410	93
1900	2000	497	27	1	525	395	25	1	421	946	54
2000	2100	504	24	0	528	365	22	2	389	917	48
2100	2200	308	8	0	316	228	12	0	240	556	20
2200	2300	192	7	0	199	115	9	0	124	323	16
2300	2400	114	8	0	122	96	3	0	99	221	11
AM total		3502	579	28	4109	4658	620	49	5327	9436	1276
PM total		6757	637	38	7432	5970	630	46	6646	14078	1351
24Hr Total		10259	1216	66	<b>11541</b>	10628	1250	95	<b>11973</b>	<b>23514</b>	<b>2627</b>
% of Total		88.9	10.5	0.6		88.8	10.4	0.8			<b>11.2</b>

source: Ritchie Traffic Services 613-540-4481

